

**TECHNICAL MANUAL
OPERATOR, ORGANIZATIONAL, DIRECT
AND GENERAL SUPPORT MAINTENANCE MANUAL
FOR
CONTAINER, REFRIGERATED
MODEL SC209
NSN: 8115-01-016-5909**

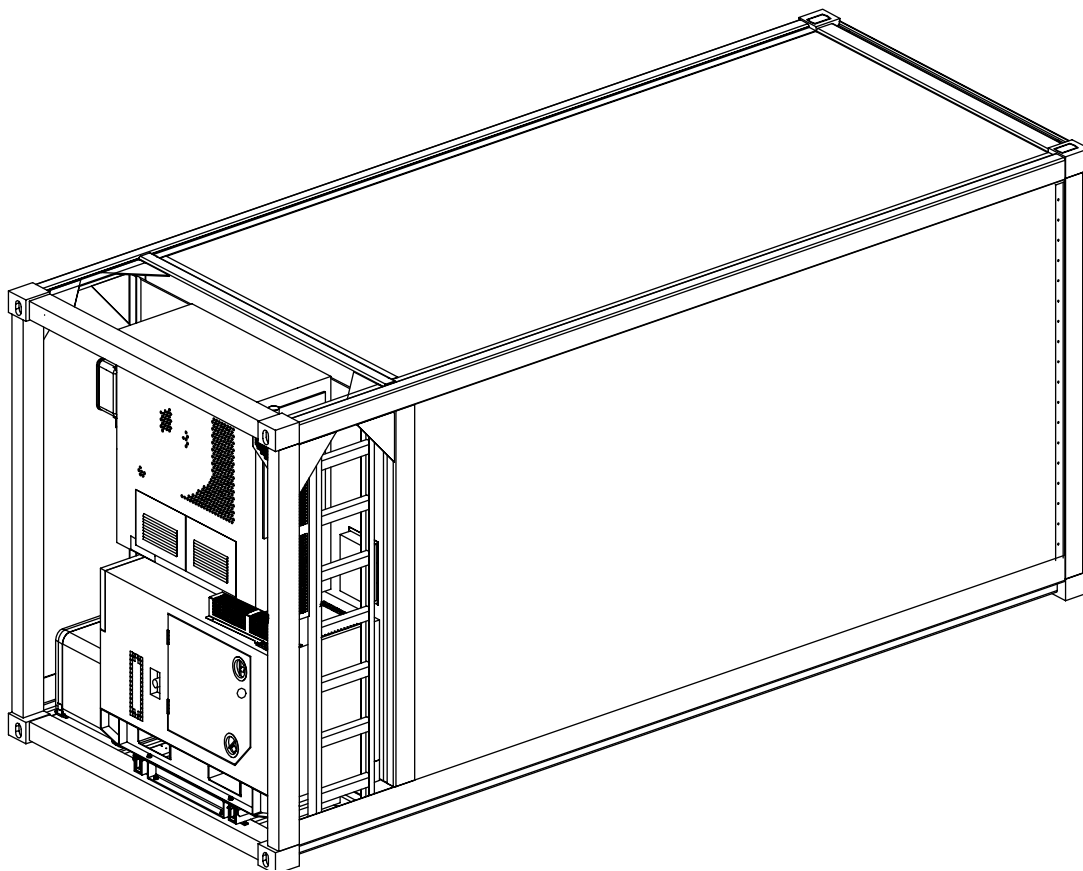

HEADQUARTERS, DEPARTMENT OF THE ARMY

WARNING

DANGEROUS CHEMICALS

are used in this equipment

DEATH

or severe burns may result if personnel fail to observe safety precautions.

WARNING

The burning of polyurethane foams is dangerous. Due to the chemical composition of polyurethane foam, toxic fumes are released when it is burned or heated. If it is burned or heated indoors, such as during a welding operation in its proximity, precautions should be taken to adequately ventilate the area. An exhaust system equivalent to that of a paint spray booth should be used. Air-supplied respirators, approved by the National Institute for Occupational Safety & Health or the U. S. Bureau of Mines, should be used for all welding in confined spaces when ventilation is inadequate. Individuals who have chronic or recurrent respiratory conditions including allergies and asthma, should not be employed in this type of environment.

WARNING

HIGH VOLTAGE

is used in the operation of this equipment

DEATH ON CONTACT

may result if personnel fail to observe safety precautions. Learn the areas containing high voltage in each piece of equipment. Be careful not to contact high-voltage connections when installing or operating this equipment. Before working inside the equipment, turn power off and ground points of high potential before touching them.

WARNING

Be sure the generator set is not operating before attempting to connect or disconnect the power cable; check to see that all switches are in the "off" or "open" position and there is no input on the load.

Never allow personnel to pass under container being lifted or moved. Always use chain and hook to hold door open to prevent injury to personnel. Always be sure no one is inside container before closing container doors. Be sure that generator set is not operating, and that exhaust lines have cooled to the point where they will not burn personnel.

In case of refrigerant leaks, do not allow refrigerant liquid to come into contact with the eyes or skin. If exposed, wash eyes and skin with fresh water.

Do not attempt service or maintenance while refrigerant unit is in operation.

Main power cable must be disconnected before performing any maintenance on the equipment.

Be sure area is well ventilated when testing for leaks with a halide torch. When the torch flame comes into contact with refrigerant, phosgene gas is released. Phosgene gas has the odor of new mown hay and can be deadly.

Use extreme care when testing or adjusting electrical circuit components if electrical power is applied. The voltages can cause serious injury or death.

The nitrogen cylinder has a normal pressure of 2,350 psig; therefore, the cylinder must be equipped with a manually operated pressure reducing and regulating valve before using to prevent a violent rupture of the system, which could result in serious injury.

Never heat any part of the refrigeration system that contains refrigerant; heat could cause expansion and explosion.

Do not release refrigerant gas in confined area; suffocation of personnel could occur.

Do not handle the oil-refrigerant mixture with your bare hands; the mixture may contain hydrochloric and hydrofluoric acids which will burn your skin. The fumes are toxic and should not be inhaled. For acid burns, wash with water immediately and get medical attention.

Before performing maintenance on exhaust system, be sure that generator set is not operating, and that exhaust lines have cooled to the point where they will not burn personnel.

Ensure that the container is properly grounded when used with an external power source.

CHANGE

NO. 5

HEADQUARTERS
DEPARTMENT OF THE ARMY
WASHINGTON, D.C., 31 December 2003

**OPERATOR, ORGANIZATIONAL, DIRECT AND
GENERAL SUPPORT MAINTENANCE MANUAL
FOR
CONTAINER, REFRIGERATED
MODEL SC209
NSN 8115-01-016-5909**

DISTRIBUTION STATEMENT A: - Approved for public release; distribution is unlimited.

TM 55-8115-202-14, 10 August 1979, is changed as follows:

1. Remove and insert pages as indicated below. New or changed text material is indicated by a vertical bar in the outer margin. An illustration change is indicated by a miniature pointing hand.

Remove pages	Insert pages
i through iii(iv blank)	i through iii(iv blank)
1-1 and 1-2	1-1 and 1-2
2-1 and 2-2	2-1 and 2-2
2-9 and 2-10	2-9 and 2-10
2-11/(2-12 blank)	2-11/2-12
3-1 through 3-6	3-1 through 3-6
4-1 through 4-6	4-1 through 4-6
4-21 through 4-29/(4-30 blank)	4-21 through 4-40
A-1/(A-2 blank)	A-1 and A-2
D-1 through D-6	D-1 through D-6
Index -3 and Index -4	Index-3 through Index-5/(Index-6 blank)
DA 2028-2	Electronic 2028 Instructions (Before DA 2028)
Cover	DA 2028 and DA2028 Reverse
	Cover
	A/B Blank

2. Retain this sheet in front of manual for reference purposes.

By Order of the Secretary of the Army

PETER J. SCHOOMAKER
General, United States Army
Chief of Staff

Official:

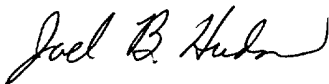

JOEL B. HUDSON
*Administrative Assistant to the
Secretary of the Army*
0335702

Distribution:

To be distributed in accordance with IDN 250496, Operator's, Unit, Direct and General Support Maintenance requirements for TM 55-8115-202-14.

This page intentionally left blank.

CHANGE }
NO.4 }

HEADQUARTERS
DEPARTMENT OF THE ARMY
WASHINGTON, D.C., 5 February 1990

Operator, Organizational, Direct and
General Support Maintenance Manual
for
CONTAINER, REFRIGERATED
MODEL SC209
NSN 8115-01-016-5909

Approved for public release; distribution is unlimited.

TM 55-8115-202-14, 10 August 1979, is changed as follows:

1. Remove and insert pages as indicated below. New or changed text material is indicated by a vertical bar in the margin. An illustration change is indicated by a miniature pointing hand.

Remove pages	Insert pages
2-3 and 2-4	2-3 and 2-4
4-5 and 4-6	4-5 and 4-6
5-1 and 5-2	5-1 and 5-2
6-1 and 6-2	6-1 and 6-2
B-1 and B-2	B-1 and B-2
C-1 and C-2	C-1 and C-2
D-5 and D-6	D-5 and D-6
E-1 and E-2	E-1 and E-2

2. Retain this sheet in front of manual for reference purposes.

By Order of the Secretary of the Army:

CARL E. VUONO
General, United States Army
Chief of Staff

Official:

WILLIAM J. MEEHAN, II
Brigadier General, United States Army
The Adjutant General

DISTRIBUTION:

To be distributed in accordance with DA Form 12-25A, Operator, Unit, Direct and General Support Maintenance requirements for Container, Refrigerated, Model SC209.

This page intentionally left blank.

CHANGE }
No. 3 }

HEADQUARTERS
DEPARTMENT OF THE ARMY
WASHINGTON, D.C., 27 August 1988

Operator, Organizational, Direct
and General Support
Maintenance Manual

for

CONTAINER, REFRIGERATED
MODEL SC209
NSN 8115-01-016-5909

TM 55-8115-202-14, 10 August 1979, is changed as follows:

Remove pages

4-15 and 4-16

Insert pages

4-15 and 4-16

2. Retain this sheet in front of manual for reference purposes.

By Order of the Secretary of the Army:

Official:

R. L. DILWORTH
Brigadier General, United States Army
The Adjutant General

CARL E. VUONO
General, United States Army
Chief of Staff

DISTRIBUTION:

To be distributed in accordance with DA Form 12-25A, Operator, Unit, Direct Support and General Support Maintenance Requirements for Container, Refrigerated, Model SC209.

This page intentionally left blank.

CHANGES }
NO. 2 }

HEADQUARTERS
DEPARTMENT OF THE ARMY
WASHINGTON, D.C., 24 June 1988

Operator, Organizational, Direct and
General Support Maintenance Manual

for

CONTAINER, REFRIGERATED
MODEL SC209
NSN 8115-01-016-5909

TM 55-8115-202-14, 10 August 1979, is changed as follows:

1. Remove and insert pages as indicated below. New or changed text material is indicated by a vertical bar in the margin. An illustration change is indicated by a miniature pointing hand.

Remove pages

2-1 through 2-4
4-3 and 4-4
4-9 and 4-10
4-19 and 4-20
4-25 and 4-26
A-1/A-2

Insert pages

2-1 through 2-4
4-3 and 4-4
4-9 and 4-10
4-19 and 4-20
4-25 and 4-26
A-1/A-2

2. Retain this sheet in front of manual for reference purposes.

By Order of the Secretary of the Army:

CARL E. VUONO
General, United States Army
Chief of Staff

Official:

R. L. DILWORTH
Brigadier General, United States Army
The Adjutant General

DISTRIBUTION:

To be distributed in accordance with DA Form 12-25A, Operator, Unit, Direct and General Support Maintenance requirements for Container, Refrigerated, Model SC209.

This page intentionally left blank.

CHANGE }
NO. 1 }

HEADQUARTERS
DEPARTMENT OF THE ARMY
WASHINGTON, D.C., 28 February 1986

Operator, Organizational, Direct
and General Support
Maintenance Manual for

CONTAINER, REFRIGERATED
MODEL SC209
NSN 8115-01-016-5909

TM 55-8115-202-14, 10 August 1979, is changed as follows:

1. Remove and insert pages as indicated below. New or changed text material is indicated by a vertical bar in the margin. An illustration change is indicated by a miniature pointing hand.

Remove pages

i through iii/iv
1-1 and 1-2
4-15 and 4-16

4-17 and 4-18
D-3 and D-4

Insert pages

i through iii/iv
1-1 and 1-2
4-15 and 4-16
4-16.1/4-16.2
4-17 and 4-18
D-3 and D-4
E-1 and E-2

2. Retain this sheet in front of manual for reference purposes.

By Order of the Secretary of the Army:

JOHN A. WICKHAM, JR.
General, United States Army
Chief of Staff

Official:

MILDRED E. HEDBERG
Brigadier General, United States Army
The Adjutant General

DISTRIBUTION:

To be distributed in accordance with DA Form 12-25A, Operator, Organizational, Direct and General Support Maintenance requirements for Container, Refrigerated, Model SC209,

This page intentionally left blank.

INSERT LATEST CHANGED PAGES / WORK PACKAGES. DESTROY SUPERCEDED DATA

LIST OF EFFECTIVE PAGES / WORK PACKAGES

NOTE: The portion of text affected by the changes is indicated by a vertical line in the outer margins of the page. Changes to illustrations are indicated by miniature pointing hands. Changes to diagrams are indicated by miniature pointing hands. Changed rear matter (DA 2028 instructions, samples and blank forms) do not have change designators.

Dates of issue for original and changed pages are:

Original	0	10 August 1979
Change	1	28 Feb 1986
Change	2	24 June 1988
Change	3	27 August 1988
Change	4	5 February 1990
Change	5	31 December 2003

TOTAL NUMBER OF PAGES FOR IS 118 CONSISTING OF THE FOLLOWING:

Page No.	*Change No.	Page No.	*Change No.
Cover	5	4-21 – 4-40	5
a-b	0	5-1	4
A/B	5	5-2 – 5-4	0
i-iii/(iv blank)	5	6-1	4
1-1 and 1-2	5	6-2	0
1-3 – 1-5/(1-6 blank)	0	7-1/(7-2 blank)	0
2-1 and 2-2	5	A-1 – A-2	5
2-3	4	B-1	0
2-4 – 2-8	0	B-2	4
2-9 – 2-12	5	B-3/(B-4 blank)	0
3-1 – 3-6	5	C-1	0
4-1 – 4-6	5	C-2	4
4-7 – 4-8	0	D-1 – D-6	5
4-9	2	E-1	1
4-10 – 4-14	0	E-2	4
4-15	3	Index-1 and Index-2	0
4-16	1	Index –3 - Index-5/(Index –6 blank)	5
4-16.1/(4-16.2 blank)	1	Authentication Page	0
4-17	1	Electronic 2028 Instructions/(Blank)	5
4-18	0	Sample DA 2028/ DA 2028 Reverse	5
4-19	2	DA 2028 / DA 2028 Reverse	5
4-20	0		

*Zero in this column indicates an original page or work package

A/(B Blank)

(This page intentionally left blank)

TECHNICAL MANUAL

NO. TM 55-8115-202-14

HEADQUARTERS
DEPARTMENT OF THE ARMY
WASHINGTON, D.C., 10 AUGUST 1979

**OPERATOR, ORGANIZATIONAL, DIRECT
AND GENERAL SUPPORT MAINTENANCE MANUAL
FOR
CONTAINER, REFRIGERATED
MODEL SC209
NSN 8115-01-016-5909**

REPORTING ERRORS AND RECOMMENDING IMPROVEMENTS

You can help improve this manual. If you find any mistakes, or if you know of a way to improve the procedures, please let us know. Mail your letter, DA Form 2028 (Recommended Changes to Publications and Blank Forms), or DA Form 2028-2 located in the back of this manual directly to: Commander, U.S. Army Tank-automotive & Armament Command, ATTN: AMSTA-LC-CECT, Kansas St., Natick, MA 01760. You may also submit your recommended changes by E-mail directly to: <amssbriml@natick.army.mil>. A reply will be furnished directly to you. Instructions for sending electronic 2028 may be found at the back of this manual immediately preceding the hard copy 2028.

DISTRIBUTION STATEMENT A: Approved for public release; distribution is unlimited.

TABLE OF CONTENTS

	Page
CHAPTER 1 INTRODUCTION	
Section I. General Information	1-1
II. Description and Data	1-1
CHAPTER 2 OPERATING INSTRUCTIONS	
Section I. Service Upon Receipt of Materials.....	2-1
II. Movement to a New Work Site	2-2
III. Controls and Instrument	2-3
IV. Operation Under Usual Conditions	2-9
V. Operation Under Unusual Conditions	2-10
VI. Operation of Material Used With the Refrigerated Container.....	2-11
CHAPTER 3 OPERATOR'S MAINTENANCE INSTRUCTIONS	
Section I. Lubrication Instructions.....	3-1
II. Preventive Maintenance Checks and Services.....	3-1
III. Troubleshooting.....	3-5

TABLE OF CONTENTS - cont.

	Page
CHAPTER 4	ORGANIZATIONAL MAINTENANCE INSTRUCTIONS
Section I.	Service Upon Receipt of Materials 4-1
II.	Movement to a New Worksite 4-2
III.	Repair Part, Special Tool and Equipment 4-2
IV.	Lubrication Instructions 4-2
V.	Preventive Maintenance Checks and Services 4-4
VI.	Troubleshooting 4-4
VII.	Maintenance of Door Assembly 4-5
VIII.	Maintenance of Door Seals 4-9
IX.	Maintenance of Door Hardware 4-11
X.	Maintenance of Document and manual Holders 4-11
XI.	Maintenance of Floor, Front, Roof and Sides 4-15
XII.	Maintenance of Spacer Strips and Cargo Restraints 4-16
XIII.	Maintenance of Thermometer Assembly 4-16
XIV.	Maintenance of Thermometer Element 4-16
XV.	Maintenance of Fuel System 4-19
XVI.	Maintenance of Power Cable 4-22
XVII.	Maintenance of Exhaust System 4-22
XVIII.	Maintenance of Refrigeration Unit 4-26
XIX.	Maintenance of Generator Set 4-28
XX.	Maintenance of Generator Slide Assembly 4-37
XXI.	Maintenance of Identification Plate 4-39
CHAPTER 5	DIRECT AND GENERAL MAINTENANCE INSTRUCTIONS
Section I.	Repair Parts, Special Tools, and Equipment 5-1
II.	Troubleshooting 5-1
III.	General Maintenance 5-1
IV.	Removal and Installation of Major Components and Auxiliaries 5-2
CHAPTER 6	REPAIR INSTRUCTIONS 6-1
CHAPTER 7	MAINTENANCE OF MATERIAL USED IN CONJUNCTION WITH THE REFRIGERATED CONTAINER
Section I.	Refrigeration Unit 7-1
II.	Generator 7-1
APPENDICES	
APPENDIX A.	REFERENCES A-1
APPENDIX B.	COMPONENTS OF END ITEM LIST B-1
APPENDIX C.	ADDITIONAL AUTHORIZATION LIST C-1
APPENDIX D.	MAINTENANCE ALLOCATION CHART D-1
APPENDIX E.	EXPENDABLE SUPPLIES AND MATERIALS LIST E-1

LIST OF ILLUSTRATIONS

Figure	Page
1-1. Refrigerated Container, Right Front Three-Quarter View.....	1-3
1-2. Refrigerated Container, Left Rear Three-Quarter View.....	1-4
1-3. Refrigerated Container, Rear Inside View	1-5
2-1. Rear Door	2-4
2-2. Door Chains	2-5
2-3. Spacer Block, Stowed and Installed	2-6
2-4. Temperature Recorder With Cover Closed	2-7
2-5. Temperature Recorder With Cover Open.....	2-8
3-1. Floor Drain and Hose	3-4
4-1. Rear Doors, Lubrication Points	4-3
4-2. Door Lining Sheet, Removal and Installation	4-7
4-3. Door Gasket, Repair and Replacement.....	4-8
4-4. Door Seal, Removal and Installation.....	4-10
4-5. Door Hardware Identification.....	4-12
4-6. Document Holder, Removal and Installation	4-13
4-7. Manual Holder, Removal and Installation.....	4-14
4-8. Spacer Strips, Cargo Restraints, Removal and Installation	4-17
4-9. Temperature Recorder, Adjustment Points, Removal and Installation.....	4-18
4-10. Thermometer Element, Removal and Installation	4-20
4-11. Fuel System Components, Removal and Installation	4-21
4-12. Power Cable and Light Wiring Diagram	4-23
4-13. Exhaust System Components, Removal and Installation (Sheet 1 of 2).....	4-24
4-14. Refrigeration Unit, Removal and Installation.....	4-27
4-15. Generator Set Removal (Sheet 1 of 2).....	4-30
4-15. Generator Set Removal (Sheet 2 of 2).....	4-31
4-16. Generator Set Exhaust Removal and Installation	4-32
4-17. Generator Set Installation (Sheet 1 of 4)	4-33
4-17. Generator Set Installation (Sheet 2 of 4)	4-34
4-17. Generator Set Installation (Sheet 3 of 4)	4-35
4-17. Generator Set Installation (Sheet 4 of 4)	4-36
4-18. Generator Slide Removal and Installation.....	4-38
4-19. Identification Plate Removal and Installation	4-40
5-1. Corner Angle and Zee and Foam Insulation, Removal and Installation.....	5-3
6-1. Rupture Repair of Panel	6-2

(This page intentionally left blank)

CHAPTER 1

INTRODUCTION

Section I. GENERAL

1-1. Scope.

This manual contains instructions for the operator, organizational, direct and general support maintenance personnel maintaining the Refrigerated Container, American Air Filter Model SC209.

1-2. Maintenance Forms and Records.

Maintenance forms and records that you' re required to use are explained in DA PAM 738-750.

1-3. Hand Receipt.

Hand receipts for Components of End Item (COEI), Basic Issue Items (BII), and Additional Authorization List (AAL) items are published in a Hand Receipt Manual, TM 55-8115-202-10HR. This

manual is published to aid in property accountability and is available through: Commander, U.S. Army Adjutant General Publication Center, 2800 Eastern Boulevard, Baltimore, MD 21220-2896.

1-4. Equipment Serviceability Criteria.

This equipment is not covered by an ESC.

1-5. Destruction of Equipment to Prevent Enemy Use.

Refer to TM 750-244-3.

1-6. Administrative Storage.

Refer to TB 740-97-2 and TM 740-90-1.

Section II. DESCRIPTION AND DATA

1-7. Description.

a. Characteristics. The refrigerated container consists of framed, insulated box with a self-contained refrigeration unit and generator set as shown in Figures 1-1, 1-2, and 1-3. A temperature recorder (Figure 1-1) and an auxiliary fuel tank (Figure 1-1) are mounted near the right front corner. Fittings at the top and bottom of each corner provide points for lifting, stacking, and locking.

One spacer block (Figure 1-1) comes with each container for use when shipping two containers in tandem on a MILVAN semi-trailer chassis. The container has a switch controlled light (100W), and a ribbed floor and wall spacer strips which provide airflow channels. A vertical ladder and a short fold-down ladder section are mounted inside the box frame left front corner, and are used by personnel for access to the equipment and the roof of the container. The right door contains an emergency escape door (small hatch) which can be opened by personnel inside the refrigerated container. A slide assembly is located in the front of the container which provides a means for ease of servicing and maintaining the generator set. It also provides ease of removal and installation of the generator set from the refrigerated

container. The refrigeration unit is a self-contained, packaged unit that attaches to the front wall of the container. This unit will stabilize internal temperatures by refrigerating or heating, and operates from any 208-volt, three phase, four wire, 60 Hz power source. The generator set is a Tactical Quiet Generator (TQG), 10-kW, 60 Hz, Diesel Driven, Model MEP-803A, NSN 6115-01-275-5061. It is a self-contained, skid-mounted set, and provides electrical power to operate the refrigeration unit and the 100W interior light.

b. Capabilities. The refrigerated container can be stacked or connected in tandem for transporting and storage. With the refrigeration unit operating, the refrigerated container can maintain internal set-point temperatures of 0°F to 40°F in an ambient temperature of 100°F and 40°F in ambient to -40°F, with a full load of pre-cooled supplies. The modes of transport are limited to road, rail and sea. The methods for handling, securing and storing must be compatible with the design requirements prescribed in MIL-C-52788 and companion standards.

c. Function. The refrigerated container serves as an insulated, temperature controlled shipping and storage container.

d. Purpose. The purpose of the refrigerated container is to store perishable commodities during transport and storage.

1-8. Identification and Tabulated Data.

a. Identification. The identification (data) and instruction plates are as follows:

(1) Container Data Plate. Located on the outside of the right hand door. Specifies NSN and serial numbers, tare weight, the manufacturer and technical manual.

(2) Temperature Recorder Identification Plate. Located on the forward side of the recorder's case. Specifies the manufacturer and model number.

(3) Refrigeration Unit Identification Plate. Located on the refrigeration unit frame assembly near the electrical panel. Specifies the manufacturer, model number, electrical requirements, weight, cooling and heating capabilities.

(4) Generator Set Identification Plate. Located on the front of the generator above the fuel tank filler neck. Specifies manufacturer, model number, NSN, electrical requirements, and weight.

b. Tabulated Data.

(1) Container.

Manufacturer	American Air Filter Co., Inc Defense Products Group
Model	SC209
Tare Weight	7965 lbs. (3612 kg)
Max. Gross Wt.	44,800 lbs. (20,20 KI)
Shipping Cube (external)	1280 cu. ft (9.26 cu. m)
Nom. Outside Dimensions	8 ft x 8 ft x 20 ft
Auxiliary Fuel Tank Capacity	26 gallon (U.S.)

(2) Temperature Recorder.

Manufacturer	Partlow
Model	TRLW

(3) Refrigeration Unit.

Manufacturer	American Air Filter Co., Inc Defense Products Group
Model	CH609-81
Type	Vapor Cycle
Power	Electrical driven, three phase, 60 Hz, four wire, 208-vac, 16-ampere
Weight	818 lbs
BTU/HR	9,000 cooling
BTU/HR	7,000 heating
Charge	18 lbs
Refrigerant	R-12

NOTE

Refer to TM 5-4110-231-14 for additional data.

(4) Generator Set.

Model	MEP-803A
NSN	6115-01-275-5061
Load Capacity	10kW at 60Hz
Current Ratings	
(1) 120/240 volt	52 amps
(2) 120/208 volt	34 amps
(3) 120 volt	104 amps
Engine	
(1) Manufacturer	Onan
(2) Model	DN4M-1
(3) Type of Fuel	DF-1, DF-2, DF-A, JP4, JP5,JP8
(4) Fuel Tank Capacity	9 gallon (34 liters)
(5) Fuel Consumption	1.125 gallon (4.3 liters) per hour

NOTE

Refer to TM 9-6115-642-10/24 for additional data.

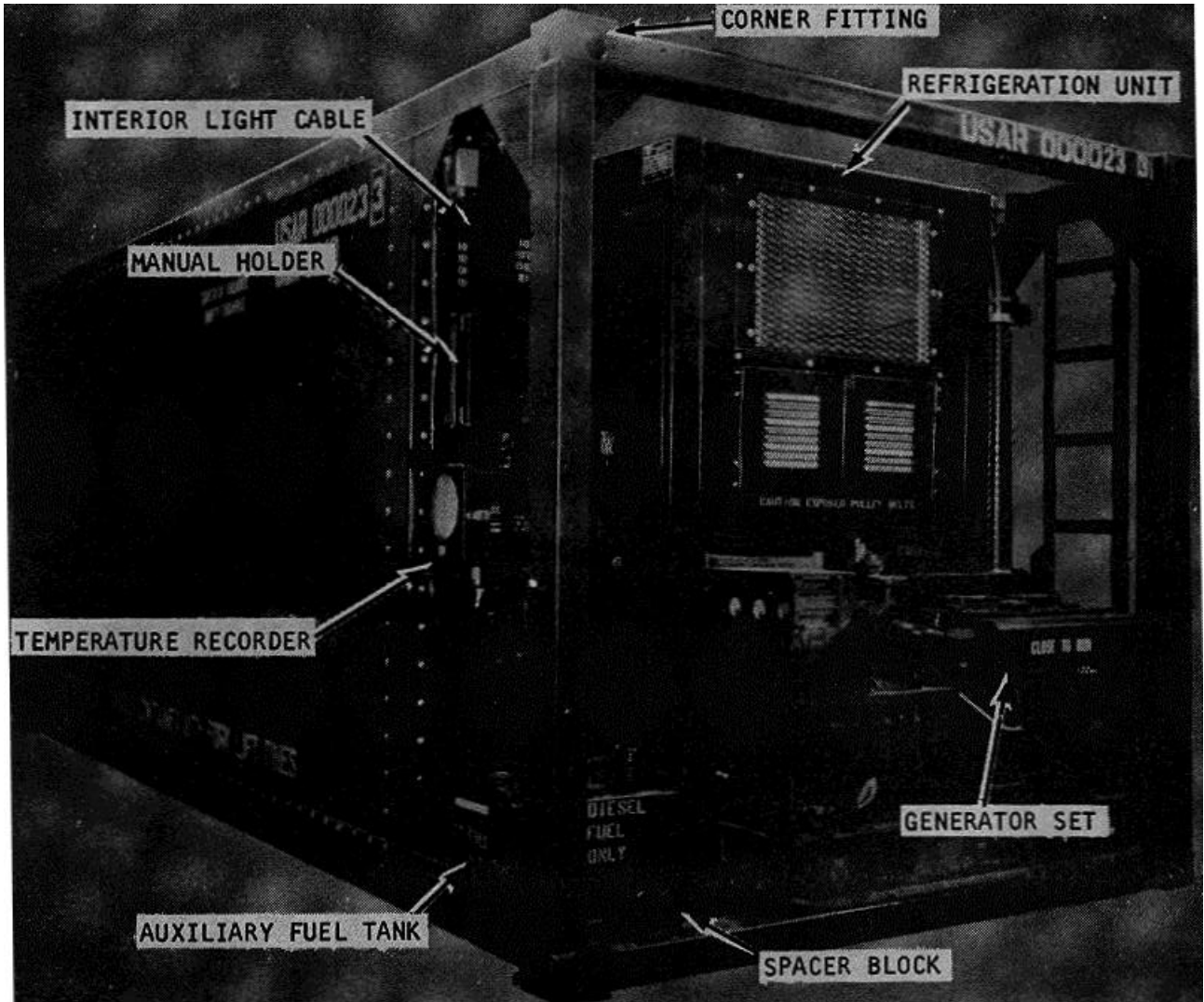

Figure 1-1. Refrigerated Container, Right Front Three-Quarter View.

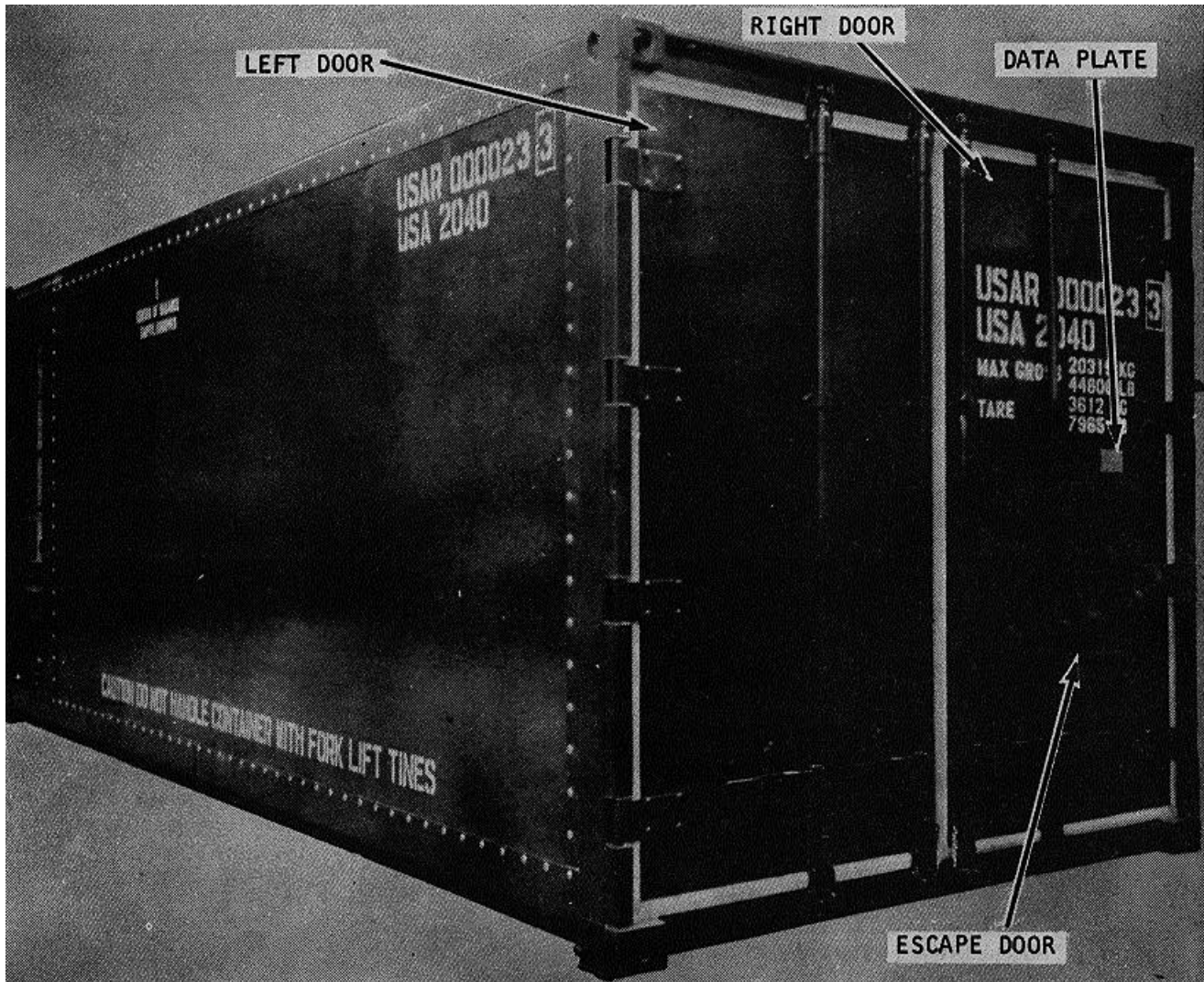

Figure 1-2. Refrigerated Container, Left Rear Three-Quarter View.

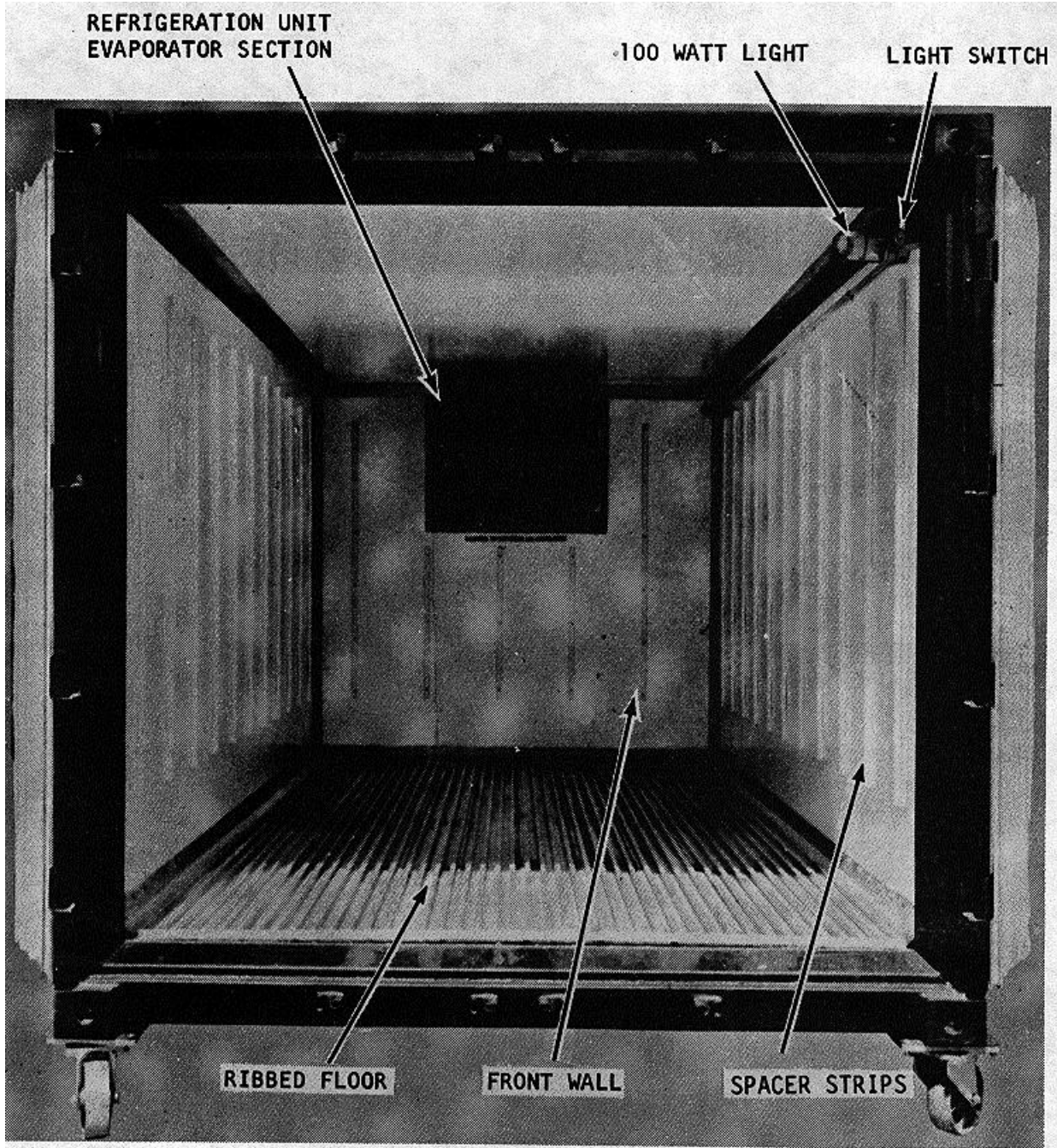

Figure 1-3. Refrigerated Container, Rear Inside View.

1-5/(1-6 blank)

This page intentionally left blank.

CHAPTER 2

OPERATING INSTRUCTIONS

Section I. SERVICE UPON RECEIPT OF MATERIAL

2-1. Inspecting and Servicing the Equipment.**a. Inspection.****(1) Container.**

(a) Inspect container doors and weather seals for damage.

(b) Inspect roof, sides and front for damage.

(c) Inspect all painted surfaces for deterioration and damage.

(d) Inspect floor drain hoses for damage, kinks, or deterioration.

(e) Inspect the temperature recorder for obvious damage.

(f) Inspect exhaust line extensions for damage and tight connection to generator set.

(g) Inspect auxiliary fuel tank and line for obvious damage and line connection tightness at both ends.

(2) Refrigeration Unit.

Refer to TM 5-4110-231-14 for inspecting and servicing requirements.

(3) Generator Set.

Refer to TM 9-6115-642-10/24 for inspecting and servicing requirements.

b. Servicing.

Perform daily preventive maintenance checks and services in Table 3-1.

2-2. Equipment Conversion.

a. General. Electrical power required to operate the refrigeration unit is supplied from the generator set or an external source. The power source conversion is accomplished by changing cable connections.

WARNING

Always be sure that the generator is not operating before attempting to connect or disconnect the power cable. Check to see that all switches are in the “off” or “open” position and that there is no input on the load. (Before connecting to external power source, ensure that the circuit breaker or switch on external power source is in the “off” or “open” position.)

WARNING

Ensure that the container is properly grounded when used with an external power source.

NOTE

Refer to TM 9-6115-642-10/24 for the Generator Set switches, and TM 5-4110-231-14 for the refrigeration unit switches.

b. Generator Power-Connection. Connect receptacle end of 5 ft. generator power cable (Figure 4-15) to connector end of refrigeration unit power cable. Connect generator cable leads (Figure 4-12) to electrical box terminals on generator set (TM 9-6115-642-10/24) to obtain 208-vac, three phase power. Plug connector on interior light conduit (Figure 4-12) into convenience outlet of rear left of the TQG.

NOTE

Observe color-coding applicability noted on wiring diagram (Figure 4-12).

CAUTION

If compressor motor or fan motor on refrigeration unit runs backwards, immediately stop operation and reverse any two of the three lead connections (A,B,C) to generator set. (See Figure 4-12).

c. External Power Connections.**WARNING**

A ground wire installation is required at the container when operating in a stationary position using utility power and a power cable other than the 30-foot power cable supplied.

(1) 208-volt, three phase, four wire.

Disconnect the generator power cable from the refrigeration unit cable. Connect the 30 foot refrigeration unit cable plug to an external 230 volt, three phase, ac power source. An additional receptacle is provided for external power connection. It is stored in the refrigeration unit cable compartment.

(2) 230-volt, three phase.

Disconnect the generator power cable from the refrigeration unit cable. Connect the 30 foot refrigeration unit cable plug to an external 230 volt, three phase, ac power source. When operating in this configuration, be sure that the applied voltage does not exceed 230 volts at any time. 230 volts is the maximum operating voltage, and power sources fluctuating above this voltage due to a variation in load demand should not be used. Continuous operation of the refrigeration unit above 230 volts will result in a premature failure of the compressor and fan motors.

(3) 380 volt, 50 Hz, three phase, with 2/1 step-down transformer.

Disconnect the generator power cable from the refrigeration unit cable. Connect the 30 foot refrigeration unit cable plug to an external 380 volt, 50 Hz, three phase power source with a 2/1 step-down transformer between the power source and the refrigeration unit. When operating in this configuration be sure that the voltage at the secondary terminals does not exceed 190 volts at any time. The voltage range using 50 Hz power for continuous operation of the refrigeration unit is limited to 173 to 190 volts. Due to a reduced refrigeration capacity when operating with a 50 Hz power supply, the cargo refrigeration requirement for a given environment must be evaluated in order to prevent damage to the cargo arising from failure to maintain a desired interior temperature. To safeguard persons, properties and equipment from hazards arising from the use of electricity, all appropriate and pertinent national and local electrical codes shall be complied with.

NOTE

The 5 foot generator power cable may also be used to connect to an external power source.

Section II. MOVEMENT TO A NEW WORK SITE

2-3. Preparation to Move to a New Work site.

a. Ensure cargo is secured and meets the requirements of MTMC PAM 55-2, Management and Stuffing of Containers.

b. Be sure that the fuel tank for the generator set is filled and more fuel is available when that runs out. Check the fuel gage in the auxiliary fuel tank mounted on the refrigerated container. (For fuel consumption of generator set, refer to TM 9-6115-642-10/24).

c. Ensure all doors, panels and guards are installed and securely fastened.

d. Be sure that no personnel are inside the refrigerated container.

2-4. Movement to a New Work site.

CAUTION

Refrigerated container MILVANs require an overhead lift. Except when equipped with a top-lift device, conventional forklifts must not be used to handle MILVAN containers in any manner including lifting, tipping, sliding or pushing. Commercially developed container handling equipment (cranes, top-lift devices, front and side loaders and self-loading transporters) is suitable for handling MILVANs. Always use spreader frame when top lifting container. Containers must be lifted vertically from the four corner fittings. Do not lift container with cable slings at an angle.

WARNING

Never allow personnel to pass under container being lifted or moved.

The container may be moved by military or commercial trailer / chassis, rail, and ship.

Section III. CONTROL AND INSTRUMENTS**2-5. General.**

This section describes the various controls and instruments and provides sufficient information to insure proper operation of the refrigerated container. However, actual operating procedures are contained in Sections IV and V of this chapter.

2-6. Container.

a. Rear Doors (Figure 2-1). Always open the right door (as facing rear of container) first. To open, first release the two handle locks on the right door. Then, grip and lift slightly both door release handles to clear bottom half of handle locks, and turn the handles to fully release lock cams from lock keepers, and pull right door open. Open left door the same way. Fasten open doors to side of container using door chains (Figure 2-2). Close doors in reverse order (left door first).

WARNING

Always use chains to hold doors open to prevent injury to personnel.

b. Spacer Block. One spacer block is provided with the container (Figure 2-3) and is used when two containers are mounted front end to rear end on a 40-foot container chassis. The blocks (one from each container) are installed in the top rear corner fittings of the front container. Each block is installed finger-up into the corner fitting hole, and hangs in place. To remove blocks, lift them up slightly and pull outward till finger is free.

NOTE

A short pole of a proper strength may be used to install and remove the blocks. Insert end of pole into bottom cavity of block to do this.

c. Temperature Recorder. The temperature recorder (Figure 2-4) records the temperature inside the container. To replace chart and activate recorder, proceed as follows:

NOTE

Blank charts are stored in manual holder.

(1) Open cover and remove knurled knob (Figure 2-4).

(2) Lift pen and remove chart; then lower pen carefully.

(3) Use key to wind movement (Figure 2-5); then replace key.

(4) Lift pen and install new chart, being sure edges of chart are under the four guides; lower pen carefully.

(5) Aline chart so tip of pen is resting on line for proper day (1-to-31) and morning (M) or night (N).

(6) Install knurled knob (hand tight) while holding chart in alined position (step 5).

(7) Adjust point pressure of pen, if necessary by raising and bending pen lifter (using your hands or needle nose pliers).

(8) Replace pen, if necessary, by lifting blade holder and pulling pen outward (toward edge of recorder). Install new pen, being sure tip end is firmly mated into end slot of blade holder, with pen point facing chart.

NOTE

The pen is of felt-tip design with a built-in ink supply, and will normally write (record) for a period of 3 to 4 months. For replacement, use Partlow No. 64401 703 cartridge pen.

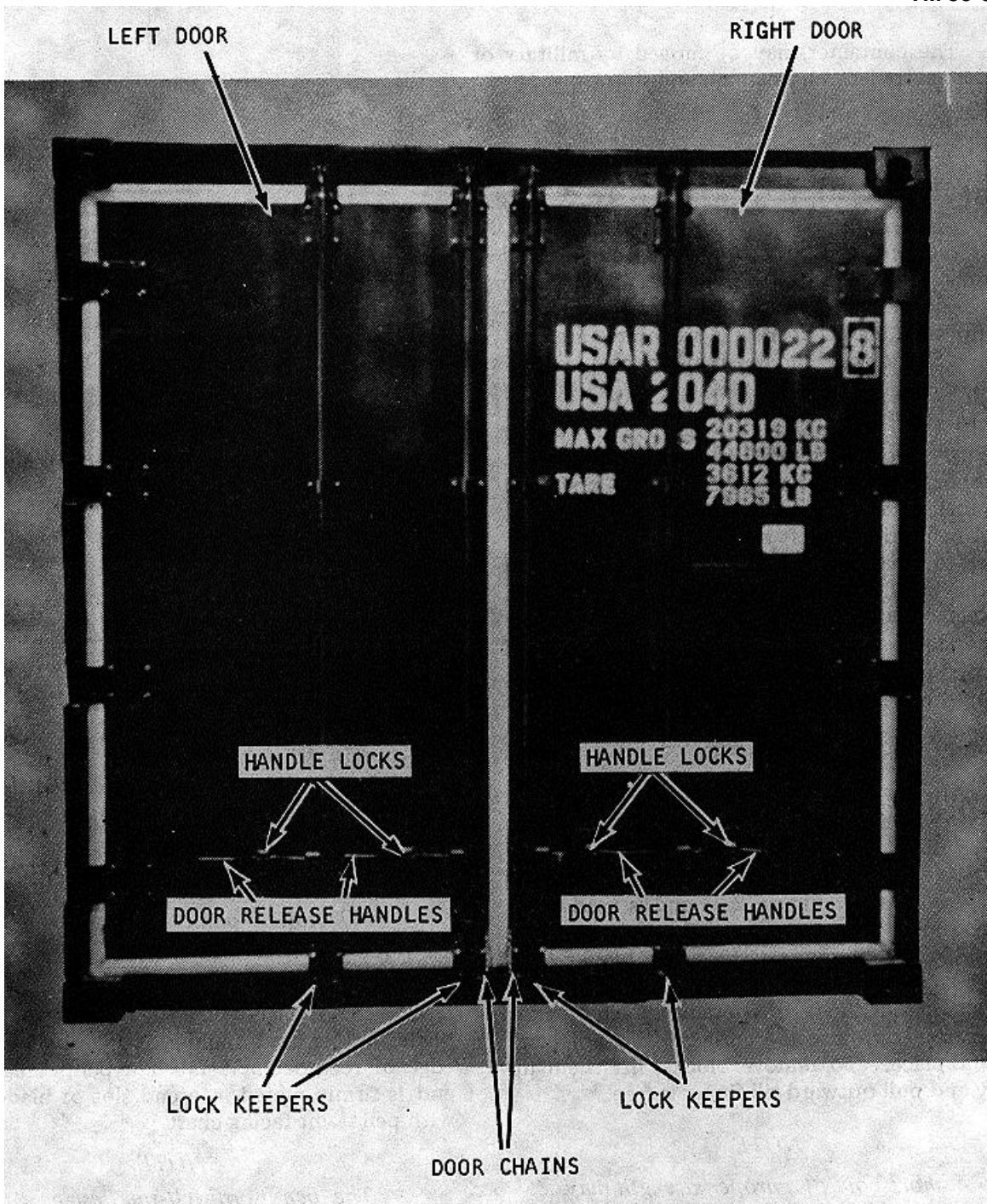
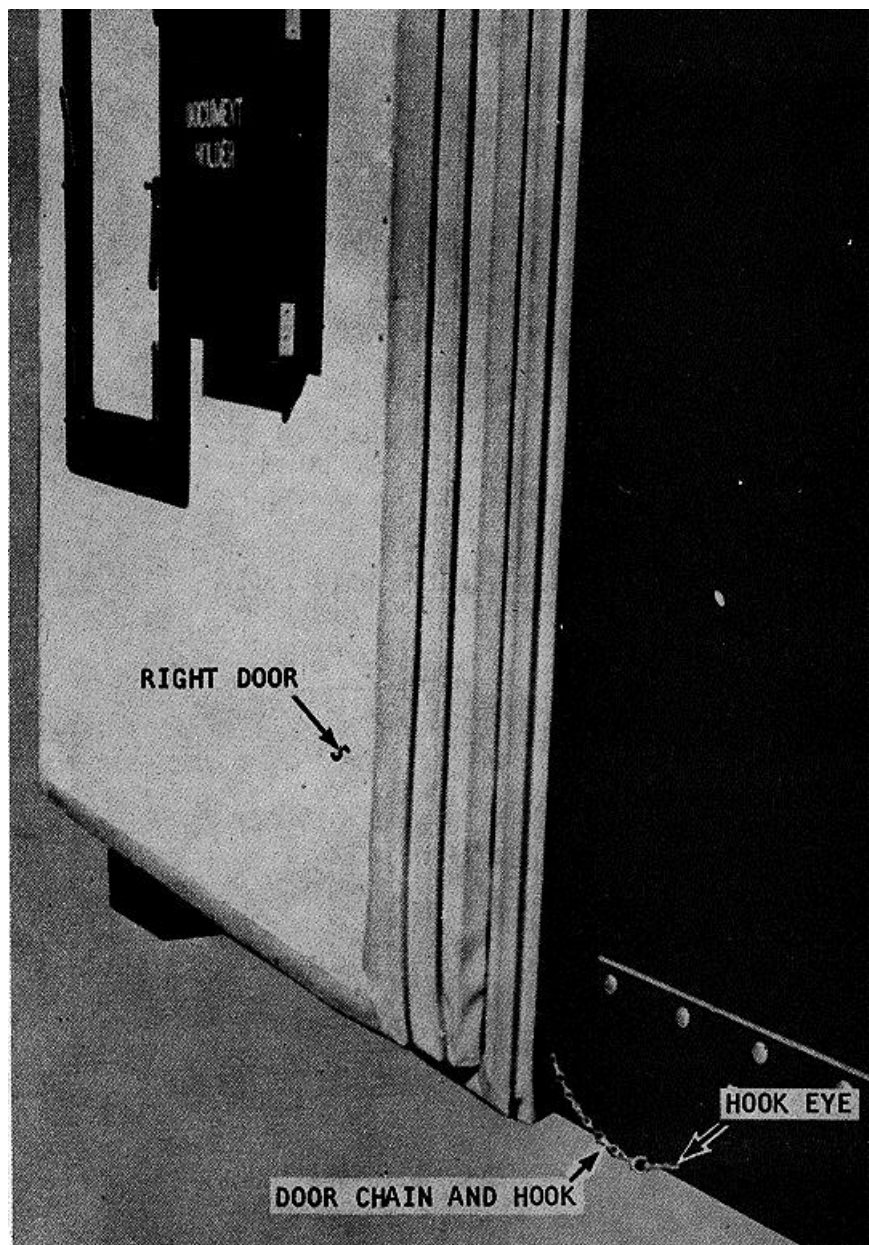
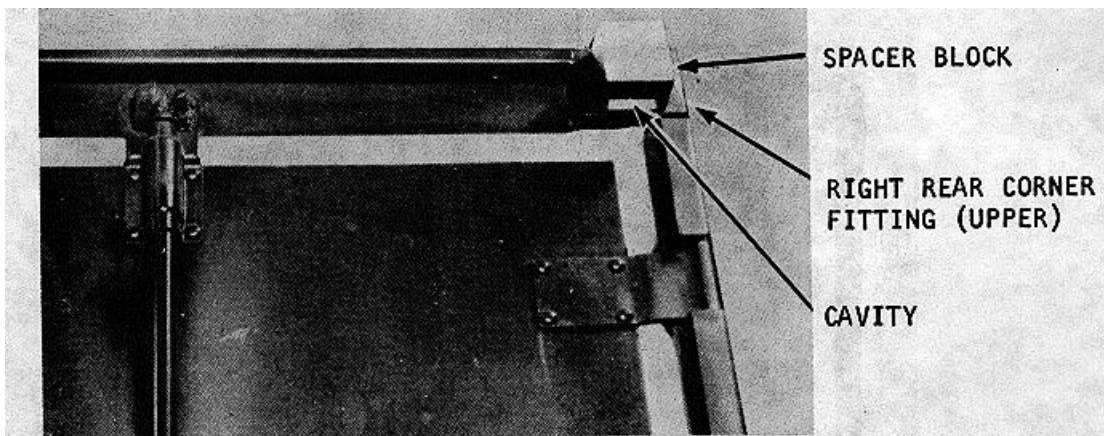

Figure 2-1. Rear Doors.



WARNING: ALWAYS USE CHAIN AND HOOK TO HOLD DOOR OPEN. A SWINGING DOOR CAN INJURE PERSONNEL.

Figure 2-2. Door Chains.



NOTE: INSTALL SPACER BLOCKS IN UPPER RIGHT AND LEFT REAR CORNER FITTINGS ON FORWARD CONTAINER ONLY.

VIEW A. SPACER BLOCK INSTALLED.

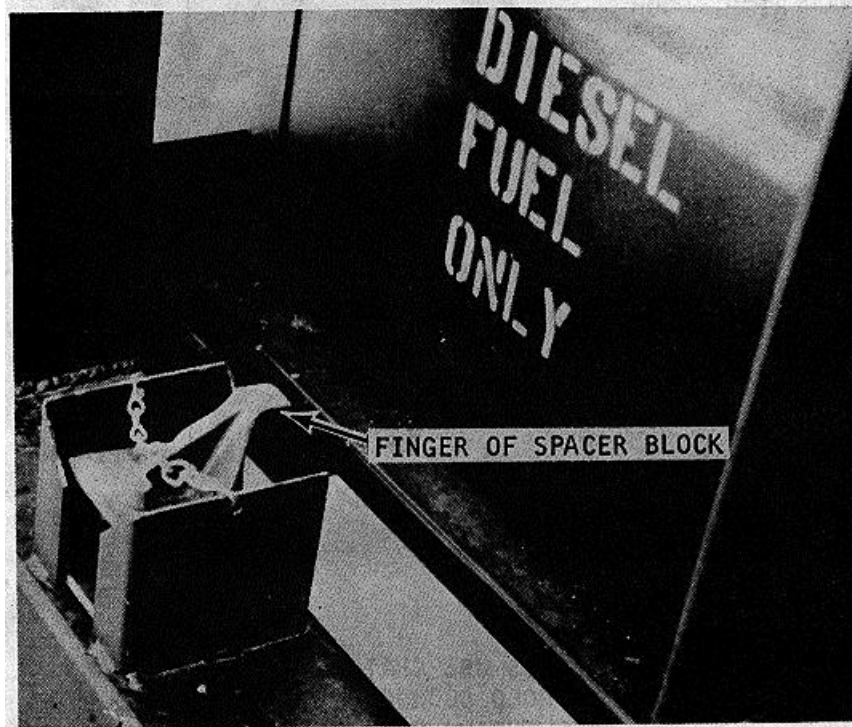

VIEW B. SPACER BLOCK STOWED.

Figure 2-3. Spacer Block, Stowed and Installed.

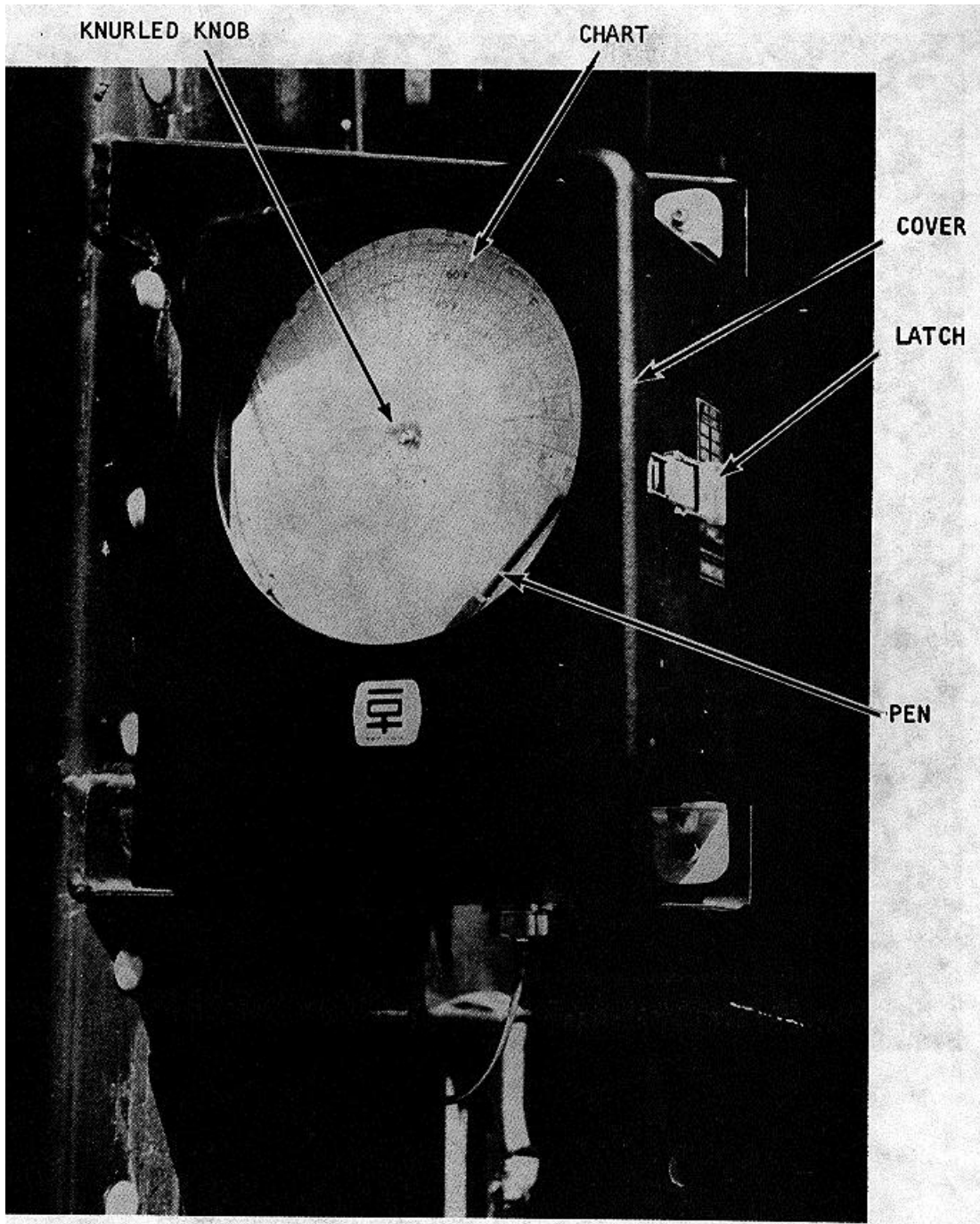
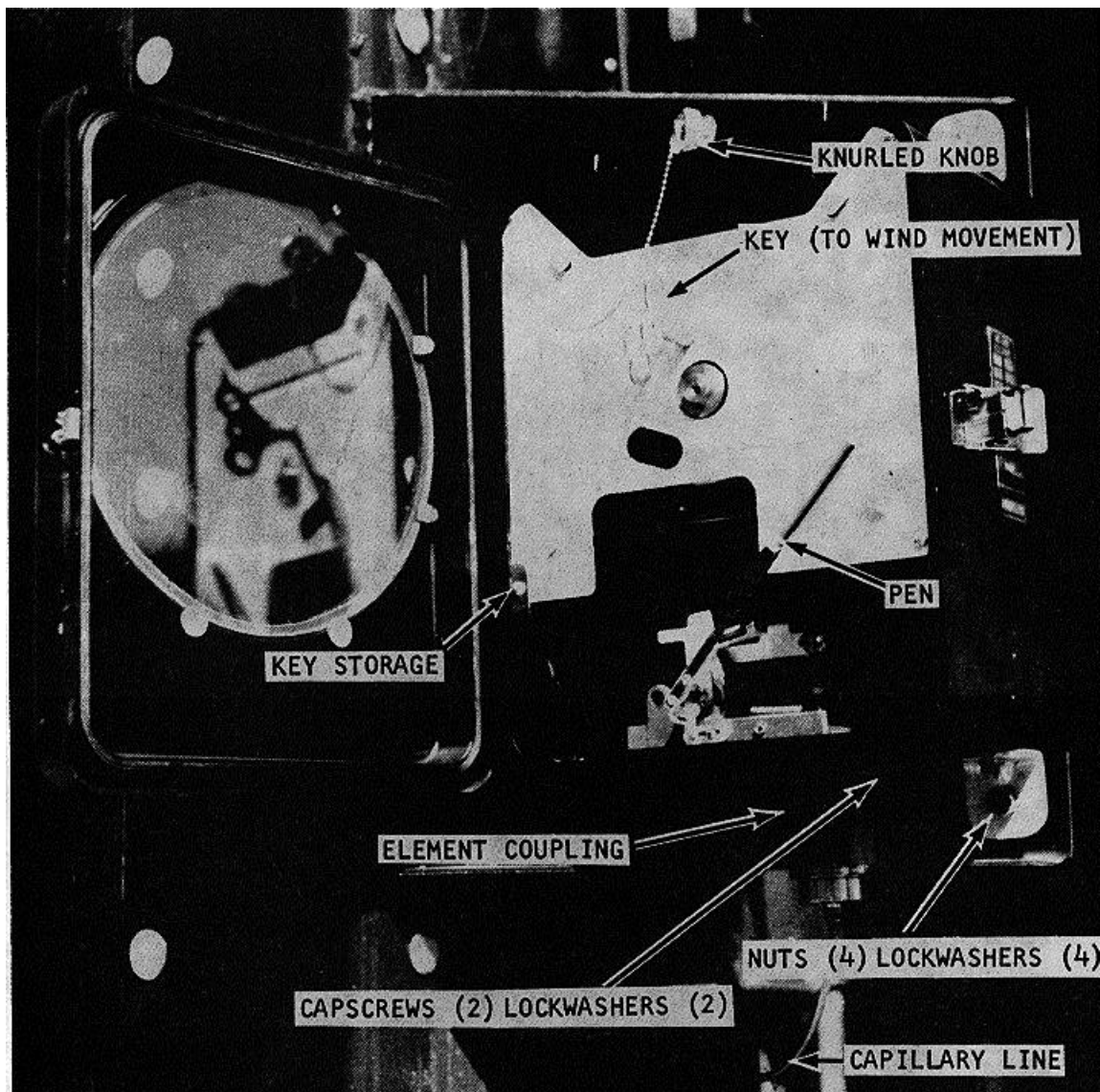

Figure 2-4. Temperature Recorder, Cover Closed.



REMOVAL:

STEP 1. REMOVE CAPSCREWS (2) AND
SEPARATE COUPLING FROM RECORDER.

STEP 2. REMOVE NUTS (4) AND RECORDER.

Figure 2-5. Temperature Recorder, Cover Opened.

(9) Adjust point pressure of pen (step 7), if necessary.

NOTE

Temperature recorder zeroing and testing is covered in Chapter 4 (paragraph 4-48).

d. Roller Slide Assembly (Figure 4-17). The roller slide assembly is mounted directly to the frame and provides a mounting platform for the generator set. Heavy gauge steel mounting plates on the roller slide are bolted to the frame and generator set. When the generator set is mounted to the roller slide, the generator set can be moved in and out from its position for servicing, maintenance and removal/replacement.

e. Power Cable. The power cable distributes electrical power from the generator set to the refrigeration unit. The receptacle end of the cable connects to the

refrigeration unit power cable. The electrical leads connect to the terminal box on the generator set.

f. Exhaust Shield and Pipes. The exhaust pipes divert hot exhaust gases from the generator set to the top of the refrigeration container. A dust cap on top of the vertical exhaust pipe prevents rain and contaminants from entering the exhaust system. The exhaust shields provide protection from the hot exhaust pipes.

2-7 Refrigeration Unit.

Refer to TM 5-4110-231-14 for the refrigeration unit controls and instruments.

2-8. Generator Set.

Refer to TM 9-6115-642-10/24 for controls and instruments on the 10 kW Generator Set.

Section IV. OPERATION UNDER USUAL CONDITIONS

2-9. Starting.

WARNING

Do not operate the generator set until it has been connected to a suitable ground. Serious injury or death can result from operating an ungrounded generator set.

NOTE

A 50-lb capacity carbon dioxide fire extinguisher should be available on a stand-by basis within the operating parameters of this equipment.

Refer to Figure 2-6.

a. Using two personnel, release retention latches (1) simultaneously and pull both sides on the generator lifting rings (2) until generator set (3) slides out and retention latches lock.

b. Refer to TM 9-6115-642-10 paragraph 2.8.1a and connect ground wire (4) end to terminal board on generator set (3).

c. Using two personnel, release retention latches (1) simultaneously, carefully push generator set (3) back into stowed position until latches lock

d. Install generator locking bolts (5).

e. Route ground wire (4) between generator set (3) and fuel tank (6).

f. Refer to TM 9-6115-642-10 paragraph 2-8.1b through g for installing ground rod (7) and connecting ground wire (4) to ground rod.

g. Close rear doors (paragraph 2-6).

h. Ensure the power source has been connected (paragraph 2-2). If generator power is to be used, refer to TM 9-6115-642-10/24 to start the generator set (3).

i. Refer to TM 5-4110-231-14 and start refrigeration unit.

2-10. Stopping.

a. Refer to TM 5-4110-231-14 to stop refrigeration unit operation.

b. Refer to TM 9-6115-642-10/24 to stop generator set operation.

2-11. Normal Operation.

CAUTION

When the temperature inside the container is to be cooled from the surrounding air temperature, do not load container until the inside has been cooled to operating temperature.

a. Ensure the unit is properly grounded (paragraph 2-9).

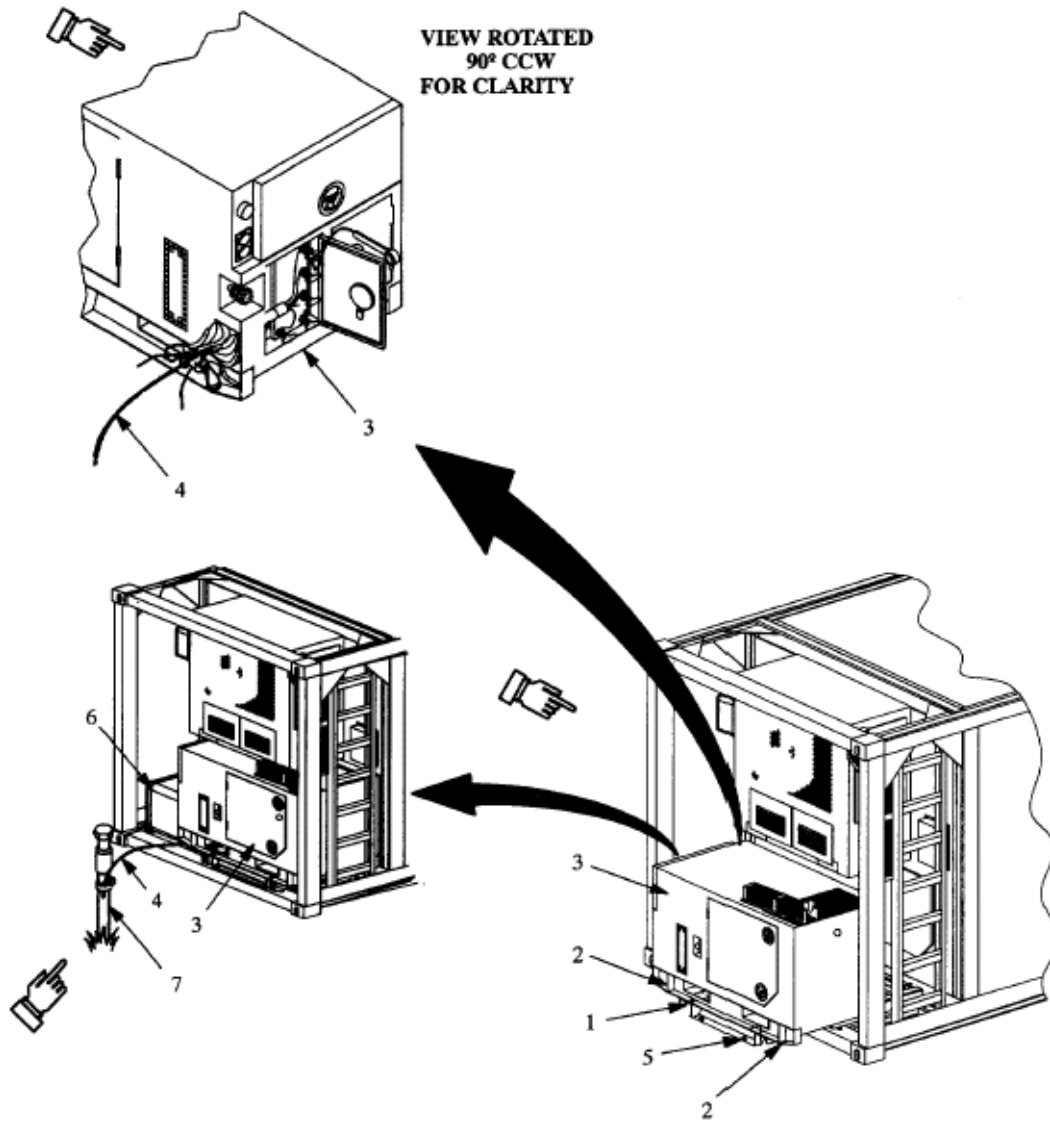

Figure 2-6. Grounding Connections.

b. Start the generator set and refrigeration unit (paragraph 2-9).

c. Check temperature readings on temperature recorder and refrigeration unit. The temperature inside refrigeration unit must change to the selected set point temperature (set on thermostat).

NOTE

If container doors are to be opened for a long time, be sure to shut down refrigeration unit as instructed in TM 5-4110-231-14. Otherwise, heavy sweating and frosting of the coils and container will occur.

d. Load the container. Refer to MTMS PAM 55-2, Guidelines for Stuffing Containers, and AMCR 5517, Stuffing of MILVAN/SEAVAN Containers.

NOTE

There must be free flow of air into and out of the evaporator (the cold coils). There must be a one foot space left at top of load, and there must be a free flow of air under and around the load.

WARNING

Be sure no one is inside container before closing container doors.

e. Close the container doors (paragraph 2-6).

f. Refer to TM 5-4110-231-14 for data that indicates refrigeration unit is operating normally.

g. Refer to TM 9-6115-642-10/24 for data that indicates generator set is operating normally.

2-12. Operation in Extreme Cold (Below 0°F)

WARNING

Do not touch cold metal parts with bare hands when operating under extreme cold conditions. Frostbite can cause permanent injury.

CAUTION

In extremely low temperatures, if doors have been open for an extended period of time, the door seals become brittle and the doors are difficult to close without damage. It then becomes necessary to operate the refrigeration system in the heating mode (above 20°F) with the doors sufficiently closed to warm the seals, or they may be heated with an external source of warm air to facilitate closing. Doors should be kept closed except during loading or unloading to prevent embrittlement damage to the door seals.

2-13. Operation in Extreme Heat.

a. Ensure the container and generator set have been properly grounded (paragraph 2-9).

b. Allow sufficient room around the refrigeration unit for proper air circulation.

c. Inspect condenser coils frequently and insure they are clean.

d. Inspect evaporator coils frequently and, if frost becomes 1/8 to 1/2 inch thick before automatic defrosting occurs, defrost coil manually (refer to TM 5-4110-231-14).

e. If possible, keep refrigeration container out of sunlight. Shade container with a tarp or similar type cover.

2-14. Operation in Dusty or Sandy Areas.

a. Ensure the container and generator set have been properly grounded (paragraph 2-9).

b. Keep container coil free of sand or foreign matter.

c. Periodically check around the control panel gasket on refrigeration unit for wear; replace if necessary.

d. Lubricate more often (paragraph 4-11). Keep all lubrication points clean and wipe up any lube spilled on the unit.

e. If possible, provide a shelter for the generator set. Use available natural barriers to shield the generator set from blowing dust or sand.

f. Wet down dusty and sandy surfaces around the generator set frequently if water is available.

g. Service engine air cleaner assembly frequently to compensate for intake of additional dust or sand.

h. Change engine oil and oil filter frequently.

i. Drain sediment frequently from the fuel/water separator. When servicing the fuel tank, be careful to prevent dust or sand entering the fuel tank.

j. Store oil and fuel in dust-free containers.

2-15. Operation Under Rainy or Humid Conditions.

a. Ensure the container and generator set have been properly grounded (paragraph 2-9).

b. Check wiring for cracked or frayed insulation. See that wiring is kept dry and waterproofed.

c. Inspect evaporator coil frequently and, if frost becomes 1/8 to 1/2 inch thick before automatic defrosting occurs, defrost coil manually (ref to TM 5-4110-231-14).

d. Inspect metal doors and frame surfaces for rust. Remove rust and apply paint or oil as applicable.

e. Make sure generator set is properly grounded to prevent electrical shock (See paragraph 2-9).

f. If possible, keep refrigeration container and generator set sheltered from rain.

2-16. Operation in Salt Water Areas.

a. Wash unit frequently with clean, fresh water. Keep water out of electrical and refrigerating equipment.

b. Inspect metal doors and frame for rust. Remove rust and apply paint or oil as applicable.

2-17. Operation in High Altitudes.

a. The refrigerated container and refrigeration unit are designed to operate at elevations up to 5,000 feet above sea level without special service or adjustment.

b. The generator set will operate up to 4,000 feet (1219.1 meters) above sea level without special adjustment or reduction in load. At elevations greater than 4,000 feet (1219.1 meters) above sea level, the kilowatt rating is reduced approximately 3.5 per cent for each additional 1000 feet (304.8 meters).

c. Above 5,000 feet the refrigeration unit output will be reduced. The condition cannot be prevented, but maximum performance can be maintained by compliance with all service instructions. Provide ample room for circulation of air through the condenser coil.

Section VI. OPERATION OF MATERIAL USED WITH THE REFRIGERATED CONTAINER

2-18. Operation of 10 kW Tactical Quiet Generator (TQG) NSN 6115-01-275-5061.

Refer to TM 9-6115-642-10/24 for instructions on starting and operating the generator set.

2-19. Operation of Other Electric Power Sources.

Refer to applicable technical manual for instructions on operating the power source.

2-20. Operation of Refrigeration Unit.

Refer to TM 5-4110-231-14 for instructions for starting and operating the refrigeration unit .

CHAPTER 3

OPERATOR'S MAINTENANCE INSTRUCTIONS

Section I. LUBRICATION INSTRUCTIONS

3-1. Container.

There are no operator lubrication instructions.

3-2. Refrigeration Unit.

Refer to TM 5-4110-231-14 for lubrication instructions

for refrigeration unit.

3-3. Generator Set.

Refer to TM 9-6115-642-10/24 for detailed lubrication instructions for the generator set.

Section II. PREVENTIVE MAINTENANCE CHECKS AND SERVICES

3-4. General.

To insure that the refrigerated container is ready for operation at all times, it must be inspected systematically so that the defects may be discovered and corrected before they result in serious damage or failure. Defects discovered during operation of the unit shall be noted for future corrections, to be made as soon as an operation has ceased. Stop operation which would damage the equipment if operation were to continue. All deficiencies and shortcomings shall be recorded together with the corrective action taken on DA Form 2404, "Equipment Inspection and Maintenance Worksheet", at the earliest opportunity. When performing your "Before Operation" (B) and "During Operation" (D) PMCS, always keep in mind the CAUTIONS and WARNINGS. After operation, be sure to perform your (A) PMCS. If your equipment fails to operate, troubleshoot with proper equipment. Report any deficiencies using the proper forms, see TM 38-750

3-5. Preventive Maintenance Checks and Services.

Refer to Table 3-1 for Preventive Maintenance Checks and Services.

a. Item Number Column.

Checks and services are numbered in chronological order regardless of interval. This column will be used as a

source of item numbers for the "TM Item Number" column on DA Form 2404 in recording results of PMCS.

b. Interval Columns.

The columns headed "B", "D", "A", "W", and "M" will contain a dot (.) opposite the appropriate check indicating it is to be performed Before, During, After, Weekly, or Monthly.

c. Item to be Inspected Column.

The items listed in this column are divided into groups and the column identifies the items to be inspected.

d. Procedures Column.

This column contains a brief description of the procedure by which the check s to be performed.

e. For Readiness Reporting, Equipment is Not Ready/Available If: Column.

This column will contain the criteria which will cause the equipment to be classified as not Ready/Available because of inability to perform its primary mission.

NOTE

If the equipment must be kept in continuous operation, check and service only those items that can be checked and serviced without disturbing operation. Make the complete checks and services when the equipment can be shutdown.

Table 3-1. Preventive Maintenance Checks and Services

NOTE: Within designated interval, these checks are to be performed in the order listed.

ITEM NO	INTERVAL					Item to be Inspected	Procedures Check for and have repaired or adjusted as necessary	For Readiness Reporting Equipment Is Not Ready/Available If:
	B	D	A	W	M			

1.	•	•	•	•		Container	<p>Check for obvious damage and leaks.</p> <p>Check floor drains (Fig. 3-1) to see that they are not covered or plugged. Check drain hoses under floor to insure they are not damaged or kinked.</p> <p>Check load to ensure that it is properly stacked.</p>	
----	---	---	---	---	--	-----------	---	--

NOTE

There must be free flow of air into and out of evaporator. There must be a one foot space left on top of load and there must be a free flow of air under and around the load.

2.	•					Temperature Recorder	<p>Check door seals for damage.</p> <p>Check for obvious damage.</p> <p>Check to ensure that the recorder is operating. Wind unit or replace chart paper as required and replace pen if not marking (Para 2-6, C).</p>	
3.	•					Refrigeration Unit	<p>Check mounting bolts to container to ensure they are tight.</p> <p>Check electrical cable connections to ensure they are tight.</p> <p>Check for obvious damage and visible liquid leaks. Refrigerant low: will not cool.</p> <p>Check for unusual noises and excessive vibrations.</p> <p>Refer to TM 5-4110-231-14 for specific items to inspect and ensure that the refrigeration unit is operating properly.</p>	

Table 3-1. Preventive Maintenance Checks and Services (Con't)

NOTE: Within designated interval, these checks are to be performed in the order listed.

ITEM NO	INTERVAL					Item to be Inspected	Procedures Check for and have repaired or adjusted as necessary	For Readiness Reporting Equipment Is Not Ready/Available If:
	B	D	A	W	M			
4.		•				Generator Unit	<p>Check capscrews (Fig. 4-15) to container to ensure they are tight.</p> <p>Check electrical connections to ensure they are tight.</p> <p>Check exhaust pipes and connections for leaks.</p> <p>Check for obvious damage, liquid leaks, unusual noise and excessive vibrations</p> <p>Refer to TM 9-6115-642-10/24 for periodic inspection and service data to ensure that the generator set is operating properly.</p>	
5.		•				Auxiliary fuel tank, line and connections.	Check for obvious damage, and fuel leaks.	

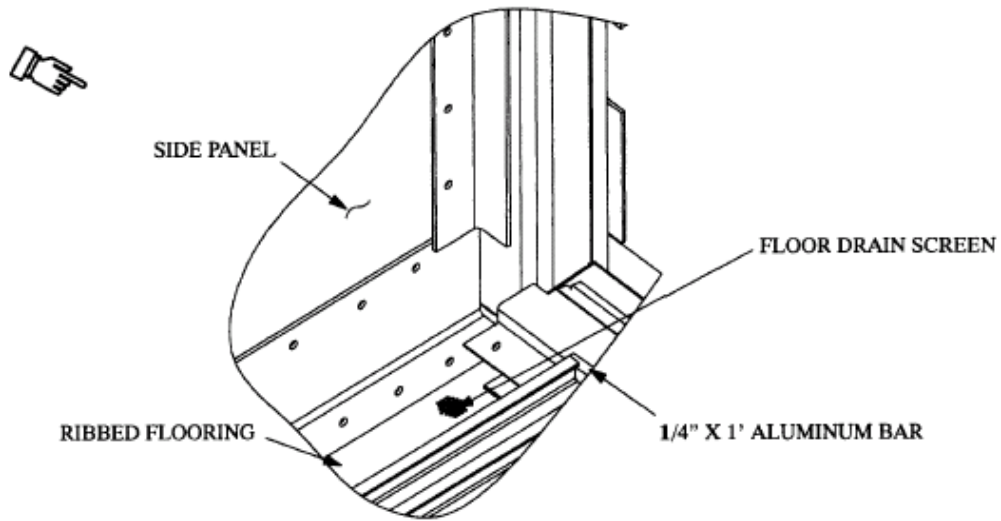

NOTE: THERE ARE FOUR FLOOR DRAINS (ONE IN EACH CORNER)

VIEW A. FLOOR DRAINS INSIDE CONTAINER.

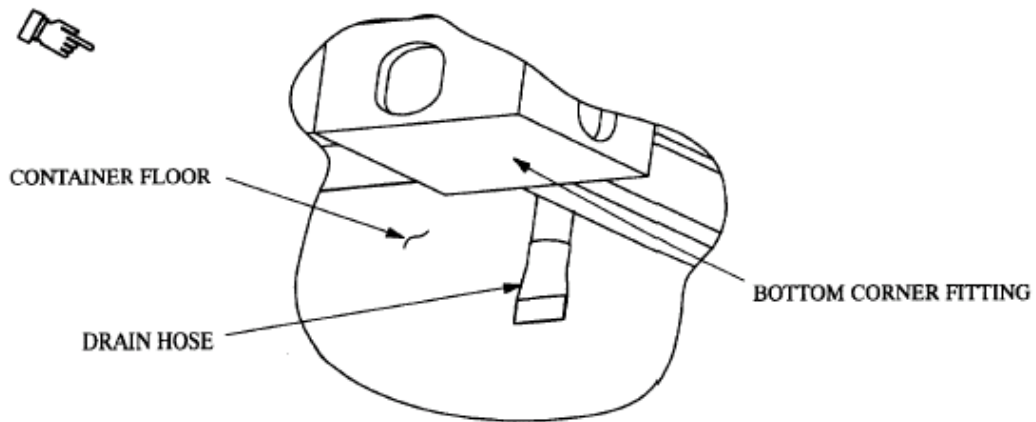

NOTE: DRAIN HOSES ARE SHORT AND SELF-CLOSING, AND AUTOMATICALLY OPEN TO DRAIN FLUIDS.

VIEW B. FLOOR DRAIN AND HOSE.

Figure 3-1. Floor Drain and Hose.

Section III. TROUBLESHOOTING

3-6. General.

a. This section contains troubleshooting information for locating and correcting most of the operating troubles which may develop in the refrigeration container. Each malfunction for an individual components, unit or system is followed by a list of tests or inspections which will help you to determine corrective actions to take. You should perform the test/inspection and corrective actions in the order listed.

b. This manual does not list all the malfunctions

that may occur, nor all tests or inspections and corrective actions. If a malfunction is not listed or is not corrected by corrective actions, notify your supervisor.

3-7. Troubleshooting Table.

Table 3-2 lists the most common malfunctions which may be found during the operation or maintenance of the refrigeration system or its components. You should perform the test/inspections and corrective actions in the order listed in Table 3-2.

Table 3-2. Troubleshooting

MALFUNCTION	TEST OR INSPECTION	CORRECTIVE ACTION
1. WATER ON FLOOR NOT DRAINING.		
	Step 1. Check for clogged floor drains.	Clean floor drains.
	Step 2. Check for kink in drain hose.	Unkink drain hose.
2. TEMPERATURE RECORDER NOT RECORDING OR SENSING PROPERLY.		
	Step 1. Check to determine if recorder is operating.	Wind recorder as required (para. 2-6c).
	Step 2. Check to see if pen is marking.	Replace pen if not marking (para 2-6c).
	Step 3. Check for proper adjustment of recorder.	Adjust recorder as follows: <ul style="list-style-type: none">a. Make certain the container temperature has stabilized.b. Open cover of recorder.c. Loosen setscrew (See Figure 4-9, View B).d. Turn shaft until pen agrees with test thermometer.e. Retighten setscrew.f. Close cover of recorder.
3. TEMPERATURE INSIDE CONTAINER ABNORMAL.		
	Step 1. Check for open or unlatched doors.	Close and latch doors.
	Step 2. Check for improperly stacked load	

NOTE

There must be a free flow of air into and out of evaporator. There must be one-foot space on top of load and there must be a free flow of air under and around the load. Refer to TM 5-4110-231-14 for proper operation of the refrigeration unit. Refer to TM 9-6115-642-10/24 to check for proper operation of the generator set.

CHAPTER 4

ORGANIZATIONAL MAINTENANCE INSTRUCTIONS

Section I. SERVICE UPON RECEIPT OF MATERIALS

4-1. Inspecting and Servicing the Refrigerated Container.

a. Inspection.

- (1) Inspect container doors for loose or damaged hinges, pins, latches, nut and bolts. Inspect gaskets and seals for damage or distortion.
- (2) Inspect roof, sides, ends and doors for holes, dents or other obvious damage.
- (3) Inspect all surfaces for deterioration and damage.
- (4) Inspect the condition of the corner posts, corner fittings and structural rail members. Containers having corner posts or rails torn, bent and kinked, or broken/cracked fittings are unserviceable and should be rejected for use. Corner posts having a small vertical dent are acceptable if the dent does not exceed 1/2 inch in depth and 12 inches in length, providing the post/corner fitting joint is not affected. If deformation of the container configuration is evident, dimensions must be checked. The overall dimensions and the variation of diagonal distances between opposite corner fittings should be within tolerances as indicated. The dimensions and tolerances below are adopted from ANSI MH5.

Overall height	8 ft (+0/-3/16 in.)
Overall length	19 ft, 10-1/2 in. (+0/-1/4 in.)
Overall width	8 ft (+0/-3/16 in.)

Variation of diagonal distance between opposite corner fittings.

Ends	(+0/3/8) in.
Top, bottom, side	(+0/-1/2) in.

- (5) Inspect floor for scrapes, holes or damaged condition.
- (6) Inspect floor drain hoses for damage, kinks or deterioration.
- (7) Inspect supporting frame members for damage or deterioration.

- (8) Inspect the temperature recorder for obvious damage.
- (9) Inspect the exhaust line extensions for damage and tight connection to generator set.
- (10) Inspect the auxiliary diesel fuel tank and line for obvious damage, and be sure that the line connections are secure at both ends.
- (11) Inspect internal light fixture and bulb for burnout or damage.

b. Servicing. Correct the deficiencies noted during inspection if they are the responsibility of organizational maintenance personnel (See Appendix B, Maintenance Allocation Chart). Otherwise, report the deficiencies to direct and general support maintenance personnel.

4-2. Inspecting and Servicing the Refrigeration Unit.

- a. Inspection. Inspect tightness of the four mounting nuts (Figure 4-14) that attach the refrigeration unit to the refrigerated container wall.
- b. Servicing. Refer to TM 5-4110-231-14 for detailed inspection and servicing of the refrigeration unit.

4-3. Inspecting and Servicing the Generator Set.

a. Inspection.

- (1) Inspect all around for damage and missing parts.
- (2) Inspect controls and wiring to ensure that all parts are dry, all connections are tight and all controls are in good conditions.
- (3) Inspect the generator set mounting hardware for tightness.
- (4) Ensure that the batteries have been installed and connected.

b. Servicing. Refer to TM 9-6115-642-10/24 for servicing of the generator set.

4-4. Cleaning, Decontamination and Painting.

Refer to Chapter 5 for general maintenance procedures covering sealing, cleaning, decontamination and painting of the refrigerated container. Refer to TM 5-4110-231-14 for the refrigeration unit and TM 9-6115-6624-24 for the Tactical Quiet Generator (TQG).

4-5. Inspecting and Servicing the Refrigeration Unit.

Electrical power for operation of the refrigeration unit is obtained from the Tactical Quiet Generator (TQG) or an external source. Refer to paragraph 2-2 for operating power conversion procedures.

Section II. MOVEMENT TO A NEW WORK SITE

4-6. Preparation to Move and Movement to a New Work Site.

Refer to Chapter 2, Section II for preparation to move and movement instructions.

Section III. REPAIR PARTS, SPECIAL TOOLS AND EQUIPMENT

4-7. Tools and Equipment.

Tools and equipment are not listed with the refrigerated container.

4-8. Special Tools and Equipment.

The following special tools are required to remove and install the Camtainer fasteners used in the refrigerated container.

- a. TORX Bit T55 (for internal drive Camtainers).

- b. TORX Socket E16 (for external drive Camtainers).

Each tool has a fluted end which engages the Camtainer nut to transmit torque. The T55 tool utilizes a 1/4 inch drive and the E16 a 1/2 inch drive on standard size ratchets and power wrenches.

4-9. Maintenance Repair Parts.

Repair parts are listed and illustrated in TM 55-8115-202-24P.

Section IV. LUBRICATION INSTRUCTIONS

4-10. General.

This section contains specific lubrications for the refrigerated container. This lubrication is performed quarterly (every three months).

Lubrication instructions for the refrigeration unit and the Tactical Quiet Generator (TQG) set are referenced.

4-11. Container Lubrication.

- a. Lubricate lock keepers as shown in Figure 4-1.

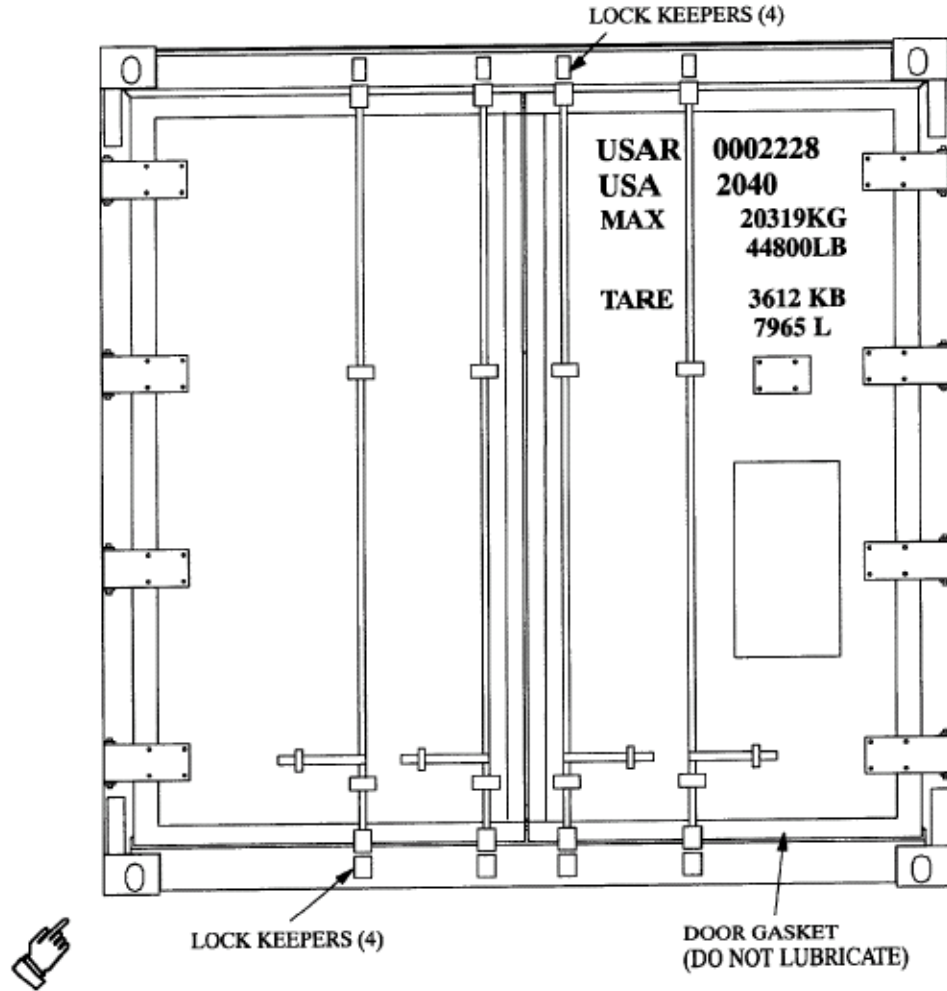

- NOTE:**
1. USE GRAPHITE GREASE CONFORMING TO VV-G-671 ON ALL LOCK KEEPERS.
 2. DOOR SEALS (INSIDE) ARE LUBRICATED WITH SILICONE GREASE OR SPRAY.

Figure 4-1. Rear Doors Lubrication Points.

b. Lubricate door seals (Figure 4-4) with silicone spray.

4-12. Refrigeration Unit Lubrication.

See TM 5-4110-231-14 for lubrication instructions for the refrigeration unit.

Section V. PREVENTIVE MAINTENANCE CHECKS AND SERVICES

4-14. General.

Inspect and service the Refrigerated Container periodically to find and correct defects before they result in serious damage or failure. Stop operation immediately if a deficiency is noticed which would damage equipment if operations were continued. Record all deficiencies together with the corrective action taken on DA Form 2404 (Equipment Inspection and Maintenance Worksheet) at the earliest possible opportunity.

4-15. Preventive Maintenance Checks and Services.

a. **Refrigerated Container.**

(1) See Table 3-1 for the daily preventive maintenance checks and services.

4-13. Generator Set Lubrication.

See TM 9-6115-642-10/24 for lubrication instructions for the Tactical Quiet Generator (TQG) set.

(2) Quarterly preventive maintenance checks and services consist of lubrication only (paragraph 4-11).

b. **Refrigeration Unit.**

See Table 3-1 for the daily preventive maintenance checks and services, and TM 5-4110-231-14 for specific checks and services.

c. **Tactical Quiet Generator (TQG) Set.**

See Table 3-1 for the daily preventive maintenance checks and services, and TM 9-6115-642-10/24 for specific checks and services.

Section VI. TROUBLESHOOTING

4-16. Scope.

This section provides information useful to organizational maintenance personnel in diagnosing and correcting unsatisfactory operation or failure of the refrigerated container.

4-17. Troubleshooting.

See Table 3-2 and 4-1 for malfunction, test or inspection, and correction action.

Table 4-1. Troubleshooting

MALFUNCTION	TEST OR INSPECTION	CORRECTIVE ACTION
1. AIR ESCAPING FROM EDGES OF REAR DOOR.	Step 1. Check for leaky door seals. Step 2. Check for damaged seals.	Repair door seals (para 4-26). Replace door seals (para 4-26).
2. TEMPERATURE RECORDER NOT RECORDING OR SENSING PROPERLY.	Step 1. Check recorder sensing element. Step 2. Check to see if pen is marking. Step 3. Inspect recorder for damage.	Replace recorder sensing element (para 4-49 and 4-50). Replace pen if not marking (para 2-6c). Replace bad recorder (para 4-45 and 4-46).
3. TEMPERATURE INSIDE CONTAINER ABNORMAL (HIGH OR LOW).		Refer to TM 5-4110-231-14 for refrigeration unit troubleshooting data.
4. GENERATOR SET NOT OPERATING PROPERLY.		Refer to TM 9-6115-642-10/24 for Tactical Quiet Generator (TQG) set troubleshooting data.
5. AIR LEAKS FROM CONTAINER.	Check to determine extent of leakage.	Seal minor leaks (para 4-39 c). Repair area that leaks (para 6-3).

Section VII. MAINTENANCE OF DOOR ASSEMBLY

4-18. Inspecting and Servicing the Refrigeration Container.

The rear door assemblies (Figure 1-2) are constructed of metal-clad plywood with a gasket type weather seal around the edges. The inner door sides (Figure 4-4) are

foam insulated and have a seal which mates with the container opening to provide an airtight closure. The document holder is mounted inside of the right door. The right door also contains an escape hatch door which opens from the inside.

4-19. Inspection.

- a. Wash doors with a detergent solution, rinse and allow to dry.
- b. Inspect door lining sheet for damage (rips, holes, gashes, loss of foam insulation).
- c. Inspect door gasket (outer weather seal) for tears, cuts, and other damage.

NOTE

The door seals are covered in Section VIII. The door hardware is covered in Section IX. The document holder and escape door are covered in Section X.

4-20. Removal of Door.

- a. Burn weld off end of hinge pins.
- b. Remove hinge pins and door.

4-21. Repair.

- a. Minor Repair of Door Lining Sheet.

(1) Remove loose chips or particles from edges of holes.

(2) Roughen entire surface around damaged area in order to allow patching material to stick better.

(3) Use repair kit Glass Reinforced Plastic Laminate MILR19907 (NSN 2090-00-372-6064), Apply epoxy furnished in kit according to instructions furnished.

- (4) Apply fiberglass tape over entire patch.

b. Major Repair of Door Lining Sheet (Up to 144 square inch).

(1) Remove loose chips or particles from edges of holes.

(2) Remove damaged foam insulation and install replacement foam (paragraph 4-21,c.).

(3) Roughen entire surface around damaged area to improve adherence properties of patching material.

(4) Use repair kit Glass Reinforced Plastic Laminate MILR19907 (NSN 2090-00-372-6054). Apply the low viscosity epoxy to cloth (furnished in kit) cut to a size at least 2 to 3 inches greater in each direction of the hole to be covered.

- (5) Affix cloth patch over damaged area.

(6) Tape cloth patch in the vertical and horizontal direction so that it will not slip while curing.

c. Foam Insulation Repair. If the area to be repaired is small (.75 cu. ft. or less), FROTH-PAK Kit 9.5 manufactured by INSTA-FOAM Products, Inc., Joliet, Illinois can be used. Remove damaged foam with a sharp tool and from the area to be patched in such a manner that a sheet of urethane insulation foam can be easily cut and placed in the area. Snugly fit the replacement foam next to the adjacent foam. The replacement foam must be the same thickness as the adjacent foam and meet the requirement of Federal Spec HH-I-530A, Type 2, Grade 2, Class 1.

d. Replacement of Door Lining Sheet. See Figure 4-2 for removal and installation instructions. Install replacement foam insulation as required (para 4-21c).

e. Door Gasket Repair and Replacement.

NOTE

To repair or replace a damaged edge, you will need the following tools: knife, screwdriver, mallet, scraper blade, brush, saw, hand caulking gun, staple gun, and a repair kit (SEA-LOK Door Kit SLRI-8S70, Metal-wood (Co.).

(1) Carefully remove corner of mitered corner tabs with sharp knife then peel off with assistance of knife blade (See View A, Figure 4-3).

(2) At the mitered corner, insert screw driver tip into the joint, prying under the web of the plastic channel. When end is loosened, pull off edging with peel back technique, prying with screwdriver as required to break loose. (See View B).

(3) Prepare the panel edge for replacement by scraping off old adhesive sealant; then brush off all loose particles.

(4) Replace corner filler tables, using staple or other small fastener, carefully locating tab on center of edge; then caulk as shown (See View C).

(5) Cut replacement edge extrusion to size by first mitering one end with saw at approximately a 45° angle; then, from the opposite end fit to door edge so that you allow approximately 1/8" clearance at each end (See View D, ref. 1/8" gap).

(6) When door edge is ready for application of edging, apply 3/16" diameter beads of SEA-LOK Adhesive Sealant 58-S-1 at the midpoints of the inside walls of the rigid channel. (See illustration on Cartridge label).

NOTES:

1. **USE REMOVED LINING SHEET FOR HOLE LAYOUT AND SIZE PATTERN (USE BULK MATERIAL FOR NEW SHEET)**
2. **INSULATION AND LINING SHEET ARE CEMENTED WITH CONTACT ADHESIVE**

REMOVAL:

- STEP 1. REMOVE DOOR (PARA 4-20).
- STEP 2. REMOVE SPACER STRIPS (PARA 4-42).
- STEP 3. RIGHT DOOR ONLY: REMOVE ESCAPE DOOR AND DOCUMENT HOLDER (PARA 4-35).
- STEP 4. DRILL OUT RIVETS AROUND ALL EDGES OF LINING SHEET.
- STEP 5. PEEL LINING SHEET OFF DOOR, BEING CAREFUL NOT TO DAMAGE FOAM INSULATION.
- STEP 6. REPLACE DAMAGED FOAM INSULATION (PARA 4-21, c).

INSTALLATION:

- STEP 1. APPLY ARMSTRONG 520 CONTACT ADHESIVE TO SURFACE OF FOAM INSULATION AND LINING SHEET.
- STEP 2. PLACE NEW LINING SHEET (SEE NOTES) OVER FOAM INSULATION, BEING CAREFUL TO LINE UP RIVET HOLES.
- STEP 3. TUCK IN DOOR SEAL EDGES AND INSTALL POP RIVETS THROUGH LINING SHEET TO DOOR BOX CHANNELS.
- STEP 4. INSTALL SPACER STRIPS (PARA 4-42).
- STEP 5. RIGHT DOOR ONLY: INSTALL ESCAPE DOOR AND DOCUMENT HOLDER (PARA 4-36).
- STEP 6. INSTALL DOOR (PARA 4-22).

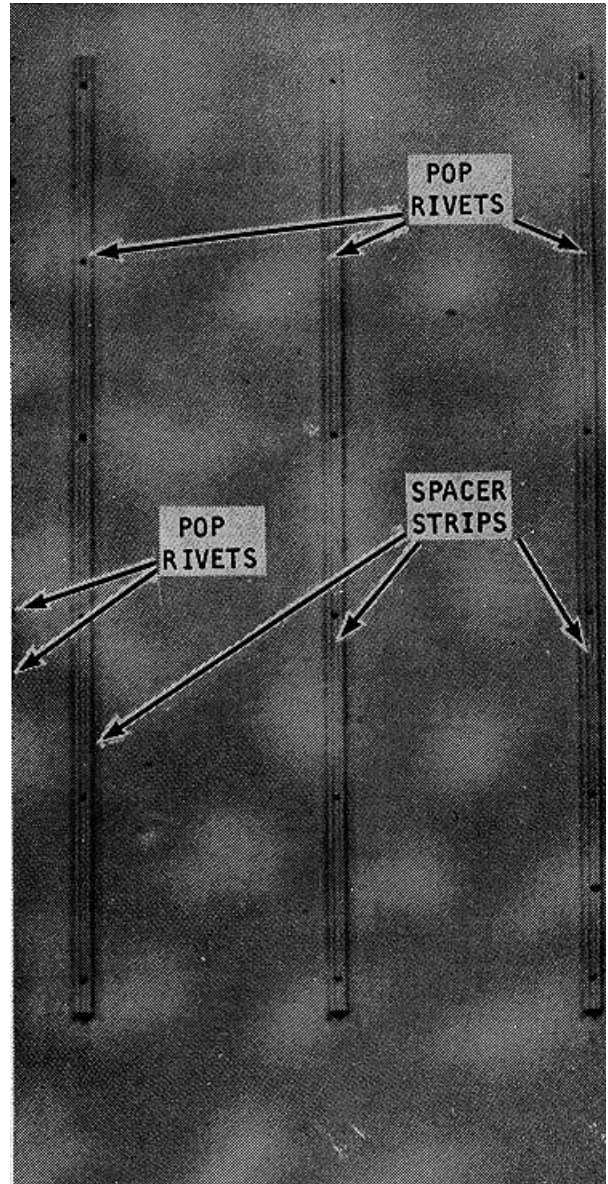
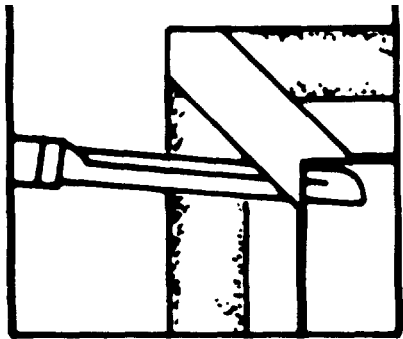
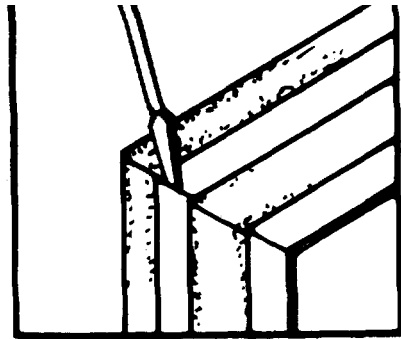

Figure 4-2. Door Lining Sheet, Removal and Installation.



VIEW A. TO REMOVE CORNER TAB



VIEW B. TO REMOVE EDGING

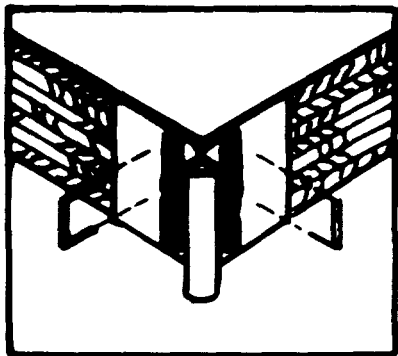

VIEW C. REPLACING CORNER TAB FILLER

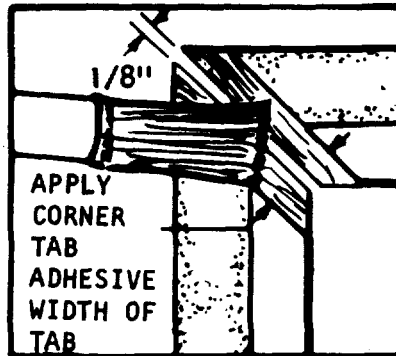

VIEW D. APPLYING ADHESIVE

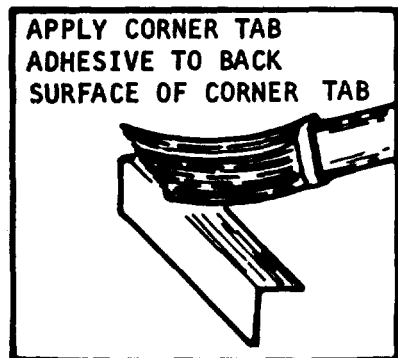

VIEW E. APPLYING ADHESIVE TO TAB

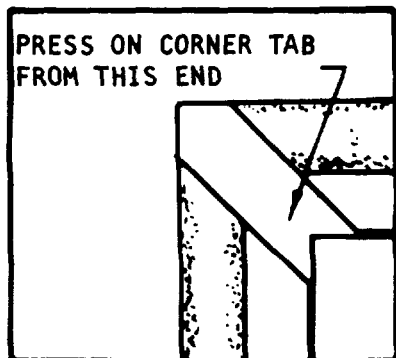

VIEW F. APPLYING TAB

TS 8115-202-14/4-3

Figure 4-3. Door Gasket, Repair and Replacement.

(7) Immediately mount the replacement edging on the panel by first spreading rigid legs on one end. Then tap edging into place progressively with wood block (fitted between flexible legs) and mallet, making sure that the edging is in place within approximately 3-minutes after applying the SEALOK Adhesive Sealant 58-S-1.

(8) To finish corners, apply the SEA-LOK Corner Tab Adhesive 58-A-1 to the edge moulding as shown in View D and to the concave surface (back) of corner tabs, 58-T-1 (View E). Let corner tab dry until

tacky, then firmly press the tab over the mitered corner joint to effect bond. This step is repeated with the Short Corner Tabs 58-T-2 on the inside joints over the shorter flexible legs. (See View D, E and F).

4-22. Installation.

- a. Install door and hinge pins.
- b. Weld hinge pins on shank end only.

Section VIII. MAINTENANCE OF DOORS SEALS

4-23. General.

The door seals (Figure 4-4) are accordion type, and made of polyvinyl and filled with polyurethane foam. The door seals provide an airtight closure when both doors are fully closed and latched.

4-24. Inspection.

Inspect door seals for tears, cuts, and other obvious damage.

4-25. Removal of Door Assembly.

Refer to paragraph 4-20 for removal.

4-26. Repair and Replacement.

- a. *Repair of cuts and tears.*

NOTE

Repair of seal is limited to taping of tears or cuts which do not exceed three inches in length, and not more than one tear in any vertical or horizontal length. Replace seal if any one tear exceeds three inches, or if more than four tears occur in one door seal.

(1) Clean surface of seal at least two inches around perimeter of seal.

NOTE

Repair of seal should be accomplished at an ambient temperature of 70° F or above.

(2) Apply 3 in. wide or wider adhesive backed polyvinyl chloride (PVC) tape to damaged area assuring that tape exceeds at least 1-1/2 in. beyond edge of tear.

NOTE

Tape is R. Mileti Co., Type RM1200.

- b. *Replacement of Seal.*

- (1) Remove door (Paragraph 4-20).
- (2) Remove pop rivets securing door seal to door lining sheet (Figure 4-4).
- (3) Remove pop rivets securing door seal to retaining strips (Figure 4-4).
- (4) Remove entire door seal from door assembly.
- (5) Install new door seal on door assembly, securing corners in place first.
- (6) Secure door seal first to retaining strips, then to door lining sheet, using pop rivets.
- (7) Install door on container (Paragraph 4-22).

4-27. Installation of Door Assembly.

- a. Install door and hinge pins.
- b. Weld hinge pin to hinge butt.

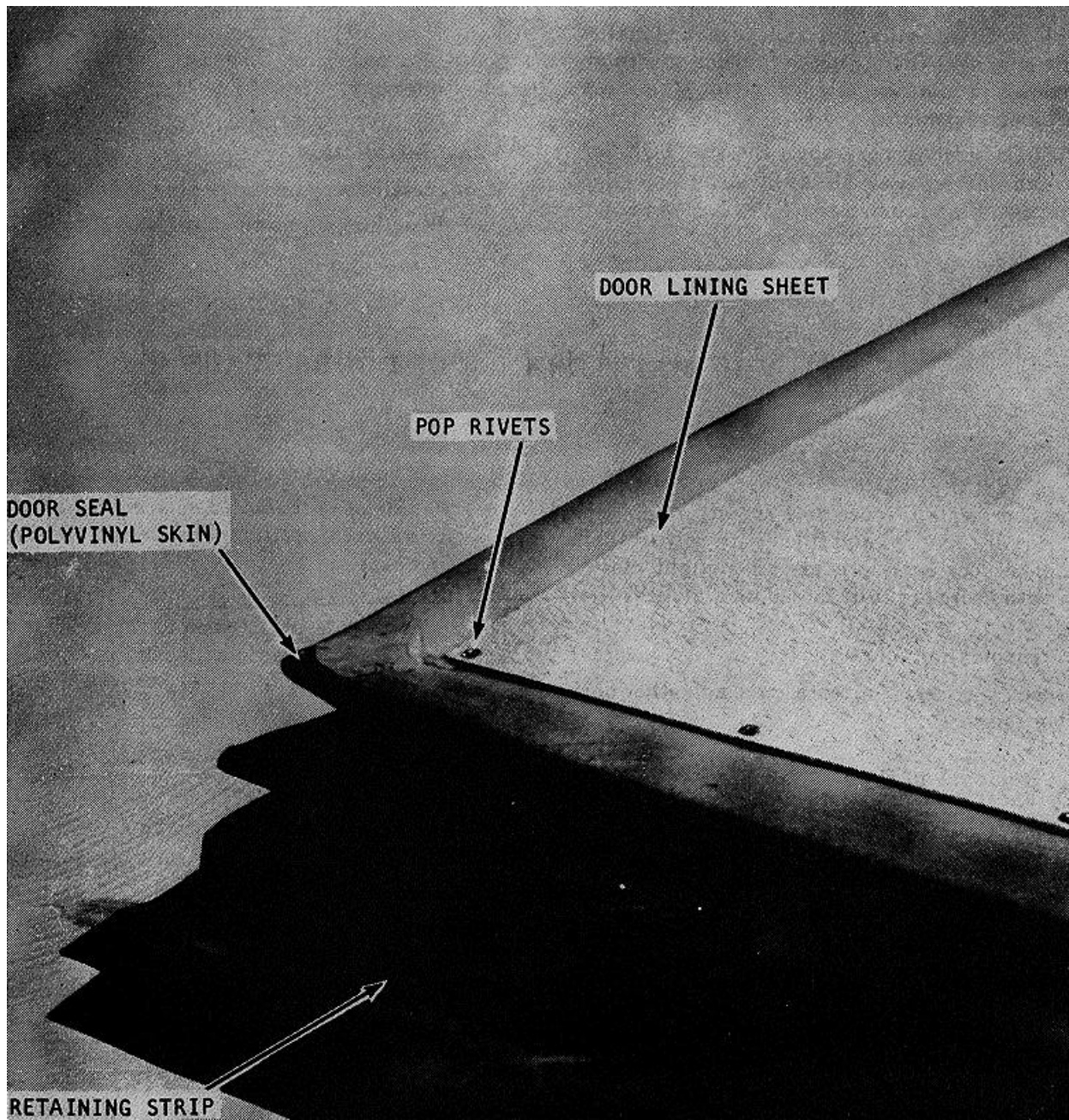

Figure 4-4. Floor Seal, Removal and Installation.

Section IX. MAINTENANCE OF DOOR HARDWARE

4-28. General.

The door hardware consists of the hinges which attach the doors to the container, the frame, and the latching mechanisms (handles, rods, guides, locks) which are operated to lock and unlock the doors.

4-29. Inspection.

a. Inspect hinges for cracks, loose bolts, and other obvious damage.

b. Inspect rod guides, rods, handles and locks for cracks, loose bolts, and other obvious damage.

c. Inspect paint on door surfaces and door hardware for excessive wear, chipping, peeling, and general condition.

4-30. Service.

a. Lubricate door hardware (Paragraph 4-11).

b. Paint door surfaces and door hardware (Paragraph 5-9).

c. Replace damaged or defective door hardware (Paragraph 4-31 and 4-32).

4-31. Removal.

a. **Door Assembly.** Refer to paragraph 4-20 for removal.

b. **Door Lining Sheet.** Refer to Figure 4-2 for removal.

c. **Foam Insulation.** Use a sharp tool to cut and remove foam over bolts attaching door hardware to be replaced (Figure 4-5).

d. **Door Hardware.** See Figure 4-5 to identify and remove damaged or defective door hardware.

4-32. Installation.

a. **Door Hardware.** See Figure 4-5 and install new door hardware.

b. **Foam Insulation.** Use a sharp tool to cut and snugly fit replacement foam insulation where removed for access to bolts. The replacement foam must be the same thickness as the adjacent foam and meet the requirements of Federal Specification HH-I-503A, Type 2, Grade 2, Class 1.

c. **Door Lining Sheet.** See Figure 4-2 for installation.

d. **Door Assembly.**

(1) Install door and hinge pins.

(2) Full weld hinge pins on shank end only.

Section X. MAINTENANCE OF DOCUMENT & MANUAL HOLDERS

4-33. General.

The document holder (Figure 4-6) and the manual holder (Figure 4-7) are metal containers used to hold shipping papers and technical data applicable to the container and its contents.

4-34. Inspection.

Inspect both holders for obvious damage and defective hardware.

4-35. Removal.

a. **Document Holder.** See Figure 4-6 for removal.

b. **Manual Holder.** See Figure 4-7 for removal.

4-36. Installation.

See applicable Figure (4-6 or 4-7) and install holder.

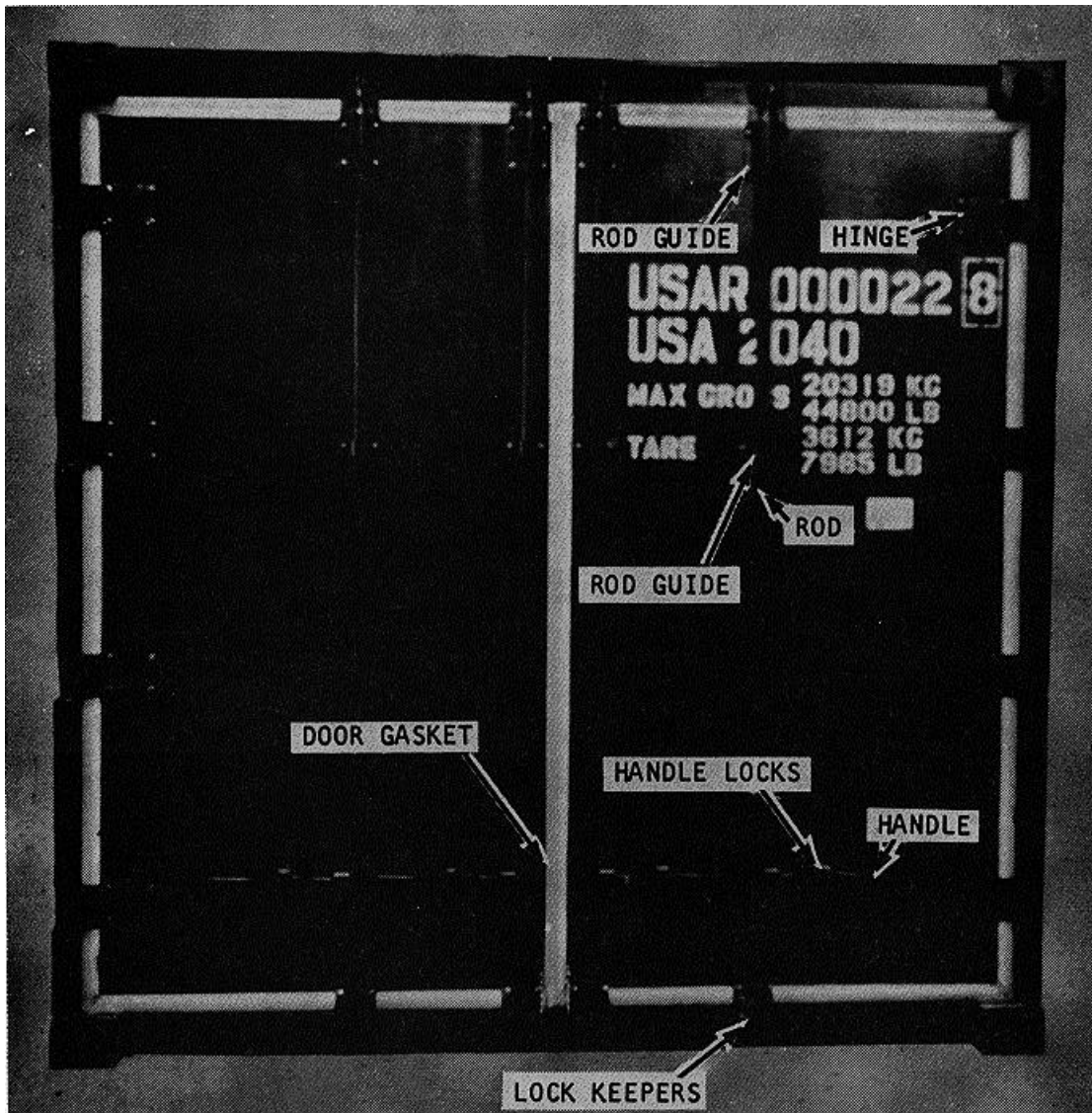

NOTE: EACH HANDLE LOCK IS ATTACHED WITH ONE CAPSCREW AND ONE CAMTAINER FASTENER. ALL OTHER DOOR HARDWARE IS ATTACHED WITH CAMTAINER FASTENERS WHICH REQUIRE THE USE OF A SPECIAL TOOL (TORX BIT T55 OR TORX SOCKET E16). THE LOCK KEEPERS ARE WELDED TO THE CONTAINER FRAME.

Figure 4-5. Door Hardware, Identification.

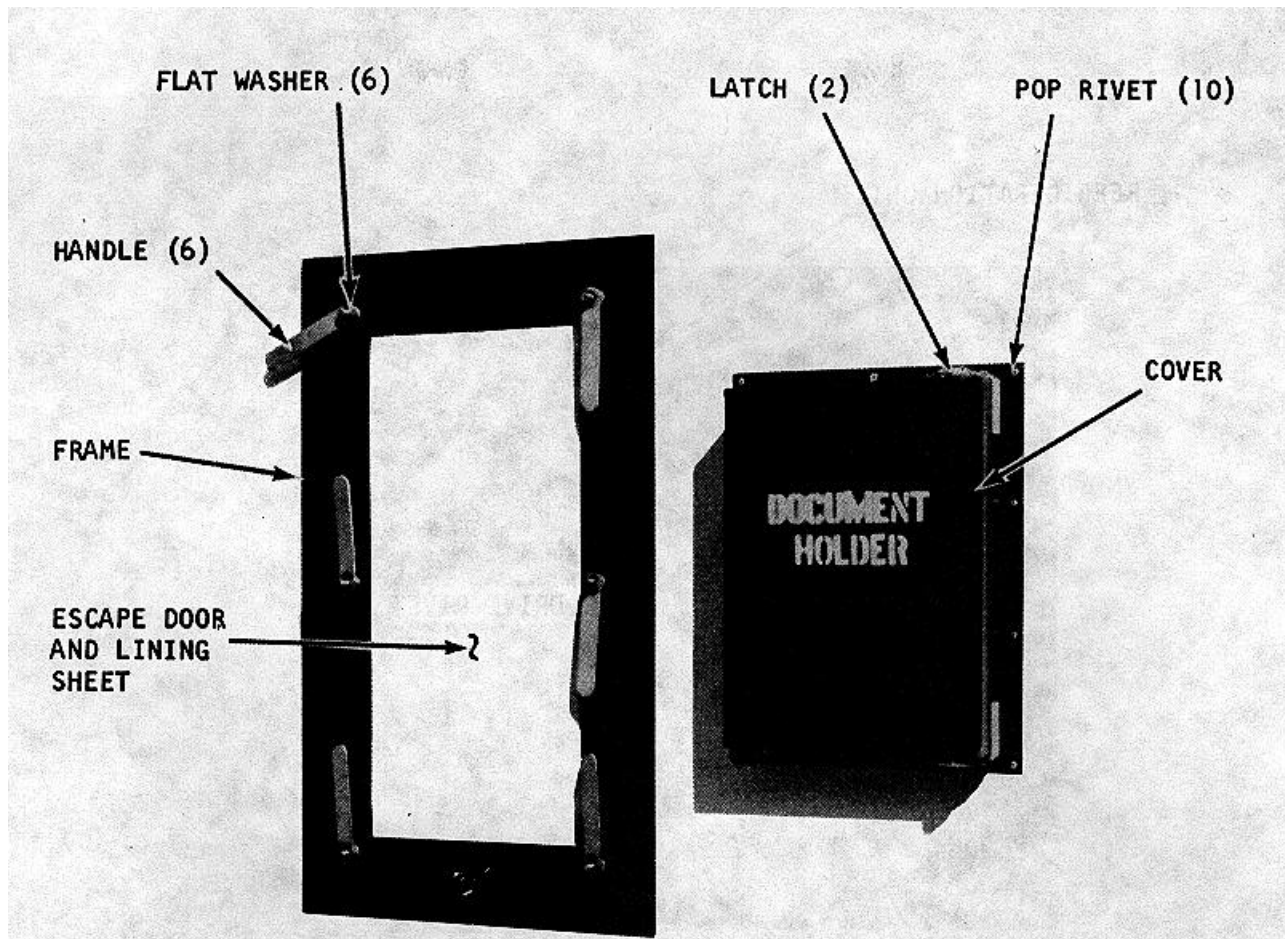

ESCAPE DOOR

REMOVAL:

STEP 1. UNSCREW 6 HANDLES, REMOVE 6 FLAT WASHERS, AND REMOVE FRAME IF LOOSE.

NOTE: ESCAPE DOOR MAY BE OPENED WITH FRAME IN PLACE. FRAME IS HELD BY 6 STUDS.

STEP 2. PUSH OUT ESCAPE DOOR AND LINING SHEET.

INSTALLATION:

STEP 1. INSTALL ESCAPE DOOR FROM OUTSIDE.

STEP 2. INSTALL ESCAPE DOOR LINING SHEET AND FRAME, AND INSTALL FLAT WASHERS AND HANDLES.

DOCUMENT HOLDER

REMOVAL:

STEP 1. OPEN LATCHES, AND REMOVE COVER AND DOCUMENTS.

STEP 2. DRILL OUT ALL POP RIVETS, AND REMOVE DOCUMENT HOLDER.

INSTALLATION:

STEP 1. INSTALL DOCUMENT HOLDER USING POP RIVETS.

STEP 2. INSERT DOCUMENTS, AND INSTALL COVER, USING LATCHES.

Figure 4-6. Escape Door and Document Holder, Removal and Installation.

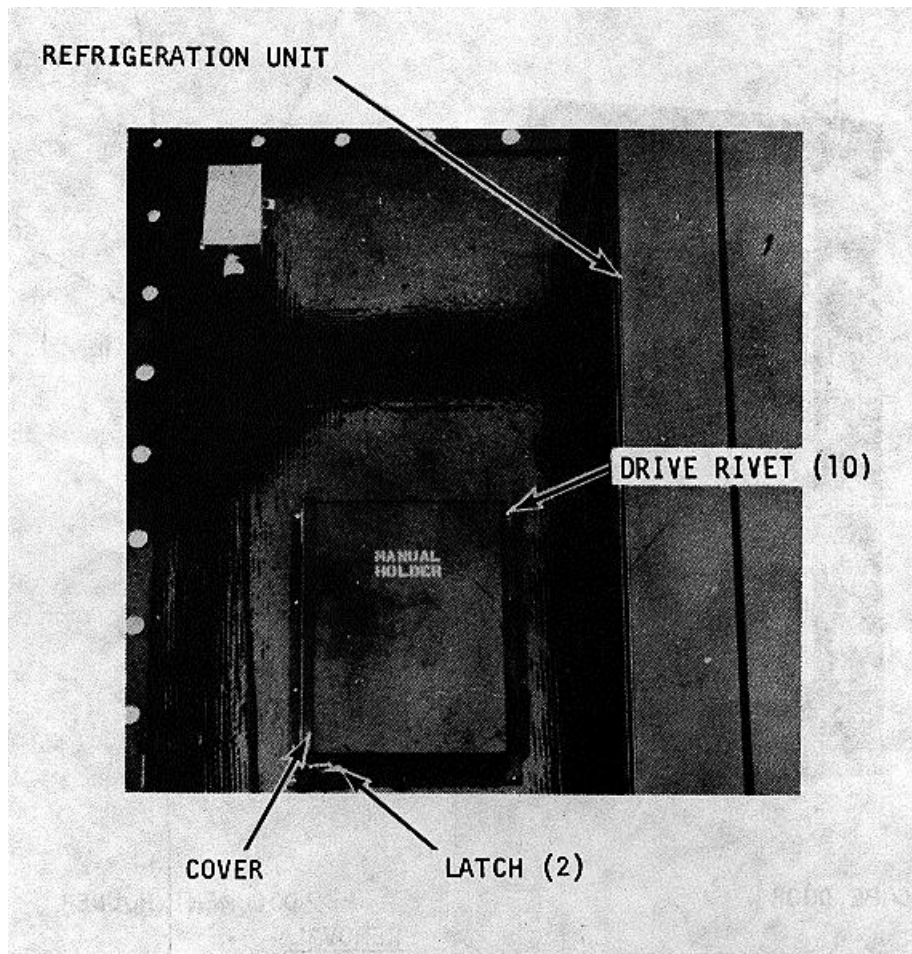

REMOVAL:

- STEP 1. OPEN LATCHES, AND REMOVE COVER AND MANUALS.
- STEP 2. DRILL OUT ALL DRIVE RIVETS, AND REMOVE MANUAL HOLDER.

INSTALLATION:

- STEP 1. INSTALL MANUAL HOLDER USING DRIVE RIVETS.
- STEP 2. INSERT MANUALS, AND INSTALL COVER, USING LATCHES.

Figure 4-7. Manual Holder, Removal and Installation.

Section XI. MAINTENANCE OF FLOOR, FRONT, ROOF, AND SIDES**4-37. General.**

The floor, front, roof, and sides of the container are one-piece, composite panel constructions (Figure 6-1) made of fiberglass reinforced plywood and polyurethane foam. The outer plywood is overlaid with fiberglass-reinforced polyester, and has a fused-on gel coat (olive drab color) on the exterior side only. The inner plywood is overlaid with fiberglass-reinforced polyester, and has a fuse-on gel coat (white colored) on the interior side only. A polyurethane foam core and rib stiffeners are bonded in between the inner and outer plywood pieces, forming an insulated composite panel. Each panel is installed in the container box assembly frame with Camtainer fasteners through holes on all edges of the outer plywood piece. The floor panel is also supported by spaced, I-beam cross members in the box assembly frame bottom. Ribbed, extruded aluminum floor board sections are placed over the floor panel to provide passages for airflow under the cargo. Surfaces of the front and side panels and doors have vertical spacer strips which provide passages for airflow down the sides of the cargo.

4-38. Inspection.

- a. Wash panels with a mild detergent and water; thoroughly rinse and allow to air dry.
- b. Inspect panels for abrasions, scrapes, punctures, and other damage.

4-39. Repair.

- a. **Minor abrasions** (glass fibers not damaged).

- (1) Remove all loose particles and clean the area (paragraph 5-8).
- (2) Trowel polyester body putting (filler) over the scrape and allow the putty to setup.

NOTE

Body putty is Cortec Fiberglass Evercoat Putty.

- (3) Level off surface with a rasp or sander.
- (4) Apply polyurethane paint (white inside, olive drab outside).

NOTE

Recommended paint is MIL-C-52261A, TT-E-485, COLOR 24087.

- b. **Scrapes** (glass fibers damaged).

- (1) Grind and dishout the damaged area.
- (2) Remove all loose particles and clean the area (Paragraph 5-8).
- (3) Apply polyurethane paint (white inside, olive drab outside).

NOTE

Recommended paint is MIL-C-52661A, TT-E-485, COLOR 24087.

- c. **Punctures** (small holes less than six inches in diameter).

- (1) Clean damaged area of fractured glass, wood, and etc.
- (2) Fill the puncture hole with polyester body putty (filler), overfilling the hole by 1/8 inch for shrinkage allowance. Cover the putty filled hole using any rigid material (hardboard, plywood, etc.) and masking tape, and leave it in place to support the putty while it sets-up.

NOTE

Body putty is Cortec Fiberglass Evercoat Putty.

- (3) Level off surface with a rasp or grinder and allow another setup period of 15 to 30 minutes.
- (4) Lightly sand area around the filled puncture hole for bonding.
- (5) Patch area using two layers of glass cloth and polyester resin from repair kit NSN 2090-00-372-6064. Apply cloth and resin according to instructions furnished in kit.
- (6) Sand smooth and apply polyurethane paint (white inside, olive drab outside).

NOTE

Recommended paint is MIL-C-52661A, TT.E-485, COLOR 24087.

Section XII. MAINTENANCE OF SPACER STRIPS AND CARGO RESTRAINTS

4-40. General.

The spacer strips (Figure 4-8) are installed on the doors, sides, and front of the container to provide an airflow passage. Spacer strips are made of soft, flexible ethylene vinyl acetate, and are 0.625 inch thick.

The cargo restraints (Figure 4-8) consists of 3 tiers of slotted tracks installed on the sides of the container, on which metal beams are inserted.

4.41. Inspection.

- a. Inspect slotted tracks (Figure 4-8) for obvious damage, defects, and attachment to container wall.
- b. Inspect beams for obvious damage and defects.
- c. Inspect the spacer strips for cuts, attachment to container wall, and other damage.

4-42. Replacement.

See figure 4-8 for removal and installation.

4-42.1. Removal

- a. Remove beams (Figure 4-8) from track.
- b. Remove sheet metal screws (Figure 4-8) from damaged slotted track and remove track.

4.42.2. Installation.

- a. Measure and cut replacement track section to fit.
- b. Cut track section on center between slots.
- c. Make sure track section is aligned with corresponding section of the opposite wall of the container.
- d. Attach track at each end with sheet metal screws (Figure 4-8).
- e. Fill each screw hole with silicone caulk, Appendix E, Item 1.
- f. Insert remaining screws.
- g. Remove screws inserted in step d, fill screw holes with silicone caulk and re-insert screws.
- h. Install beams into track.

Section XIII. MAINTENANCE OF THERMOMETER ASSEMBLY

4-43. General

The thermometer assembly (Figure 4-9) consists of a mechanical recorder and its remote sensing element. This assembly provides a record of temperatures inside the refrigerated container during operation. The chart recorder is spring operated (key wind-up), and uses replaceable charts.

4-44. Inspection.

Inspect thermometer recorder assembly (Figure 2-4, 2-5) for obvious damage, chart installation, and pen operation.

NOTE

Thermometer element is tested and recorder is adjusted in Section XIV.

4-45. Removal.

- a. Disconnect thermometer element coupling from recorder (Figure 4-9).
- b. See Figure 4-9 and remove attaching parts and thermometer recorder assembly.

4-46. Installation.

- a. Install thermometer recorder assembly and attaching parts (Figure 4-9).
- b. Connect thermometer element coupling to recorder.

Section XIV. MAINTENANCE OF THERMOMETER ELEMENT**4-47. General.**

The thermometer element (Figure 4-10) is located inside the refrigerated container, above the evaporator plenum chamber. The element senses the ambient internal temperature, and through a capillary tube and coupling, transmits it to the recorder assembly.

4-48. Testing.

- a. *Recorder adjustment.*

- (1) Make certain the container temperature has stabilized.
- (2) Open cover of recorder.
- (3) Loosen set screw (Figure 49).
- (4) Turn shaft until pen agrees with test thermometer.
- (5) Retighten setscrew.
- (6) Close cover of recorder.

Change 1 4-16.1/(4-16.2 blank)

This page intentionally left blank.

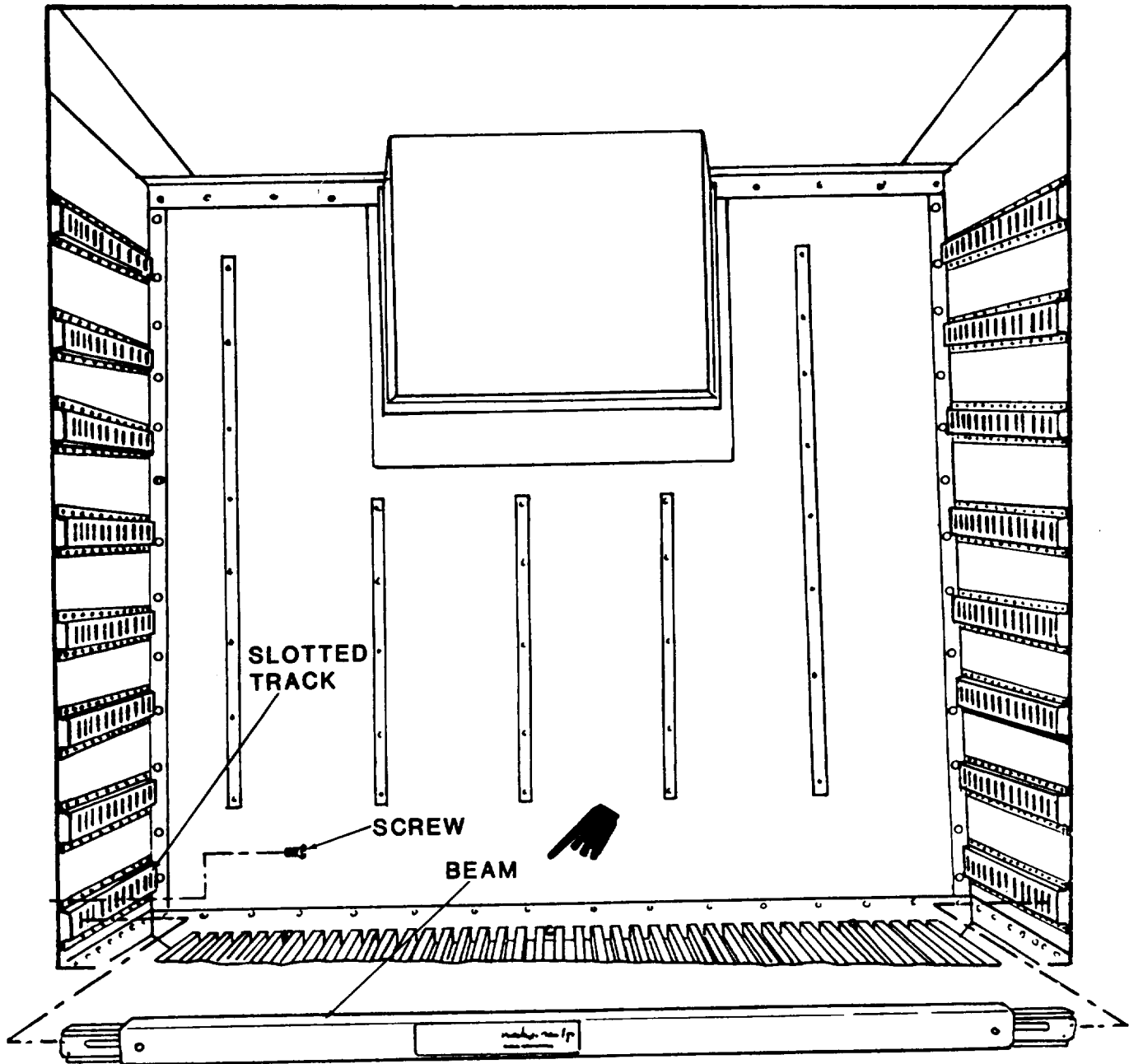

NOTE: SPACER STRIPS ON DOORS ARE FASTENED TO THE DOOR LINING SHEET WITH POP RIVETS. TO REMOVE, DRILL OUT THE POP RIVETS.

FIGURE 4-8. SPACER STRIPS, CARGO RESTRAINT, REMOVAL AND INSTALLATION

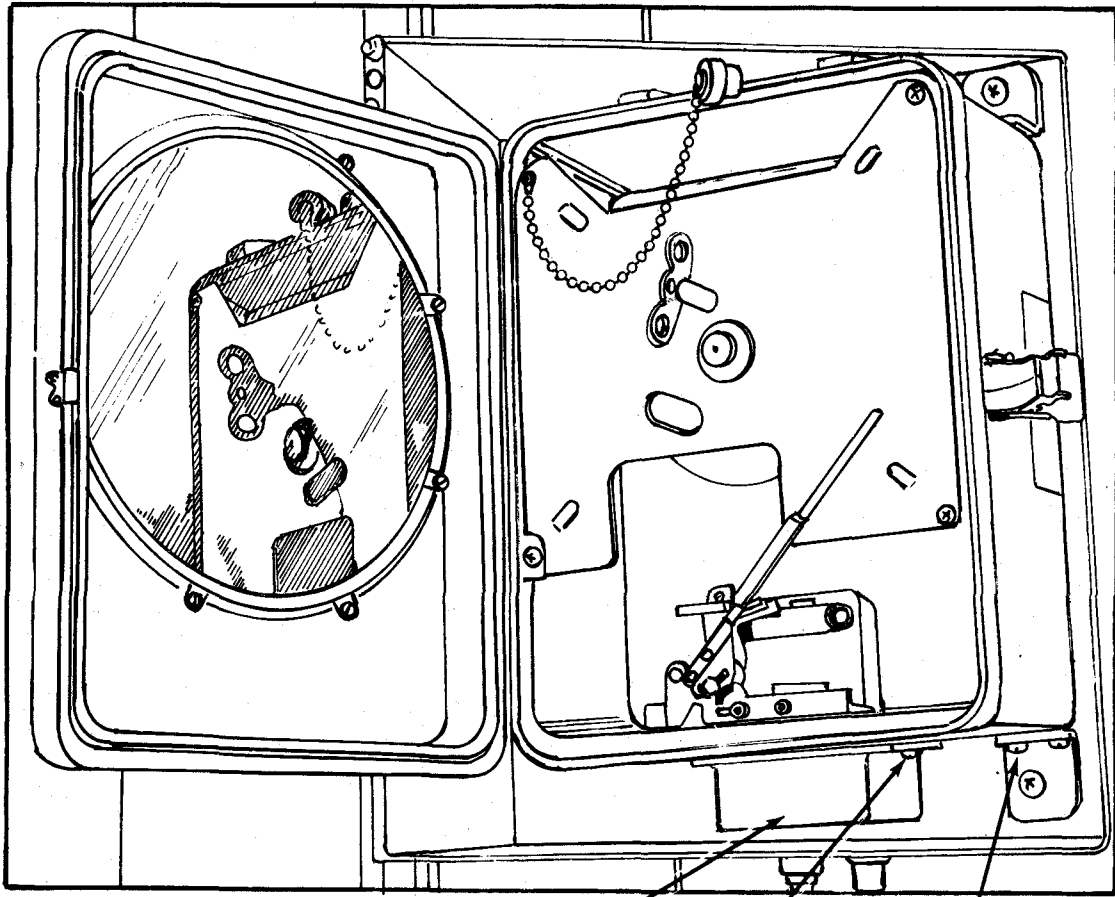

THERMAL SCREWS (2)
ELEMENT

CAPSCREWS (4)
LOCKWASHERS (4)
SHOCK MOUNT (4)

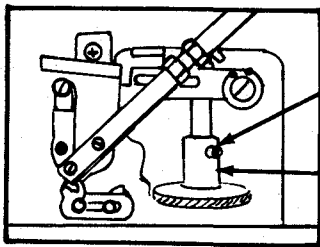

SETSCREW

PINION SHAFT

NOTE: CHART MUST BE INSTALLED ON RECORDER WHEN ADJUSTING SHAFT TO CHECK PEN INDICATION OF TEMPERATURE.

VIEW B. ADJUSTMENT POINTS

FIGURE 4-9. TEMPERATURE RECORDER, ADJUSTMENT POINTS AND REMOVAL AND INSTALLATION.

b. *Testing of thermal element with sensing element.*

(1) Perform recorder adjustment (see preceding).

(2) Reset refrigeration unit thermostat (MK410) to a setting of 5-degrees warmer or cooler.

(3) Allow container temperature to stabilize, as indicated by test thermometer, to the selected temperature.

(4) Recorder should indicate container temperature within +2 degrees of test thermometer indication; if not, replace thermal element (paragraph 4-49, 4-50).

(5) Reset refrigeration unit thermostat (TM 5-4110-231-14).

4-49. Removal of Thermal Element With Sensing Element.

a. Remove capillary line clamps and free sensing element from clips (Figure 4-10).

b. Disconnect thermal element to recorder (Figure 4-9).

c. Remove grommets and pull capillary line and element through container wall hole.

4-50. Element Installation.

a. Pass sensing element through container wall (Figure 4-10).

b. Connect thermal element to recorder (Figure 4-9).

c. Install sensing element in clips, install clamps and grommets (Figure 4-10), and seal with room temperature curing silicon rubber, Dow-Corning RTV 732.

d. Perform recorder adjustment (paragraph 448).

Section XV. MAINTENANCE OF FUEL SYSTEM

4-51. General.

The fuel line connects the auxiliary diesel fuel tank (Figure 4-11) to the generator set engine to allow extended running. The fuel tank has a vented fuel cap and a fuel gage. The fill tube extending to the level marking has a pin hole for venting purposes in case the fuel level reaches above the level marking.

4-52. Inspection.

a. **Fuel cap.** Inspect for obvious damage and defects, and verify vent passage is open including the pin hole in the fill tube.

b. **Fuel gage.** Inspect for broken glass, deteriorated gaskets, loose screws, and operation (fuel level indication versus approximate known fuel level in tank).

c. **Fuel line.** Inspect for obvious damage and defective fittings.

d. **Fuel tank.** Inspect for obvious damage, leaks, punctures, rust, and security.

4-53. Replacement.

a. **Fuel cap.** Replacement is obvious.

b. **Fuel line.** See Figure 4-11 for removal and installation.

c. **Fuel tank** (1) See Figure 4-11 for removal and installation.

(2) Repair fuel tank using epoxy patch kit NSN 8040-00-777-0631 as follows:

NOTE

Only small pinholes and cracks may be repaired with epoxy patch.

(a) Drain fuel tank to a level below holes or cracks, via drain plug in bottom of fuel tank.

(b) Remove paint and clean area to be repaired using crocus cloth or sandpaper.

(c) Mix and apply epoxy patch in accordance with instructions supplied in the kit.

(d) Allow epoxy to cure for 30 minutes or as specified in the instructions supplied.

(e) Fill fuel tank and inspect for leaks around the repaired areas.

(f) Paint repaired surface using color 24087, MIL-STD-595.

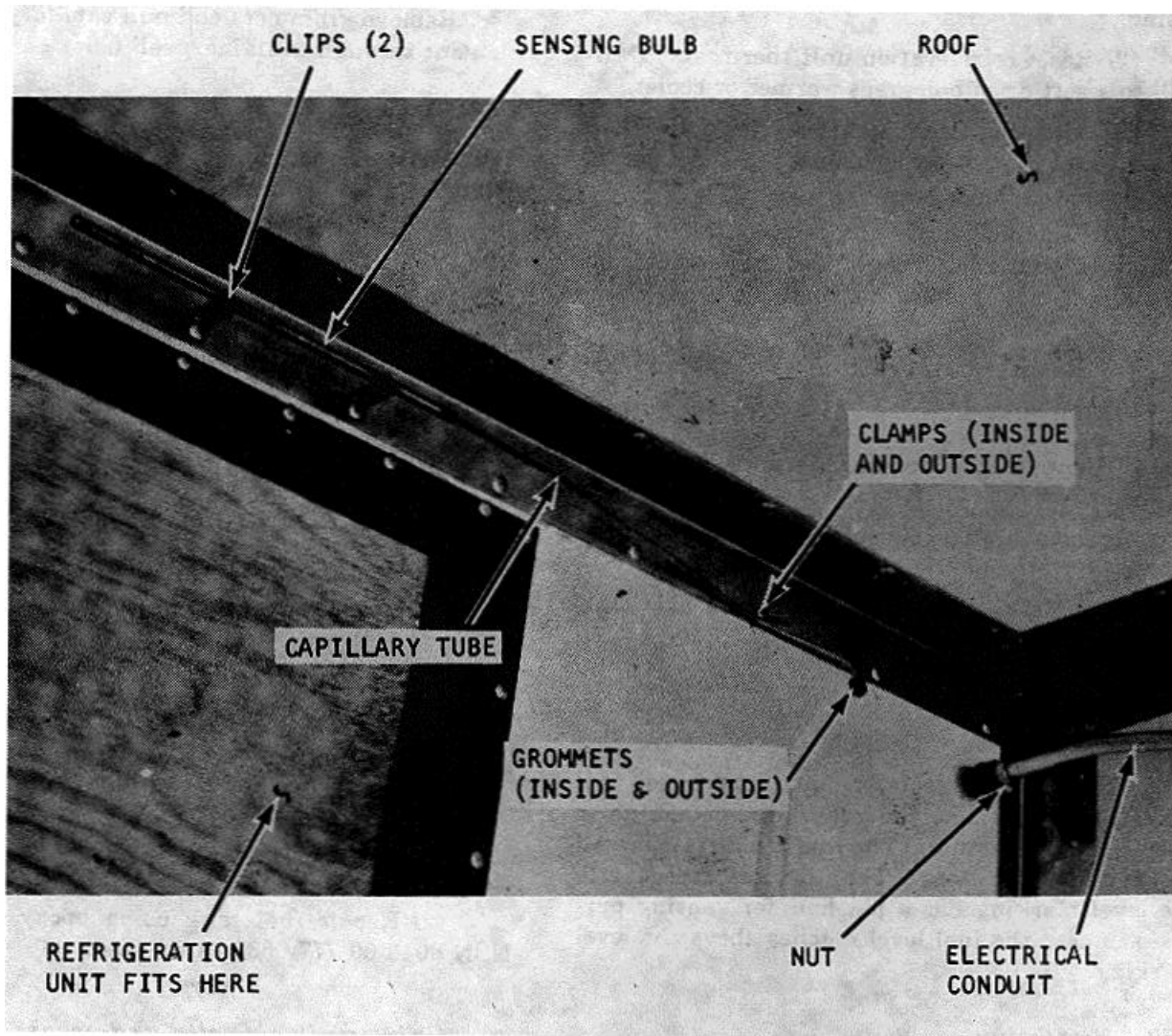

NOTE: DISCONNECT WIRES IN JUNCTION BOX ON OUTSIDE OF FRONT WALL, AND LOOSEN NUT TO SEPARATE CONDUIT ONLY WHEN REMOVING RIGHT SIDE OR FRONT.

Figure 4-10. Thermometer Element, Removal and Installation.

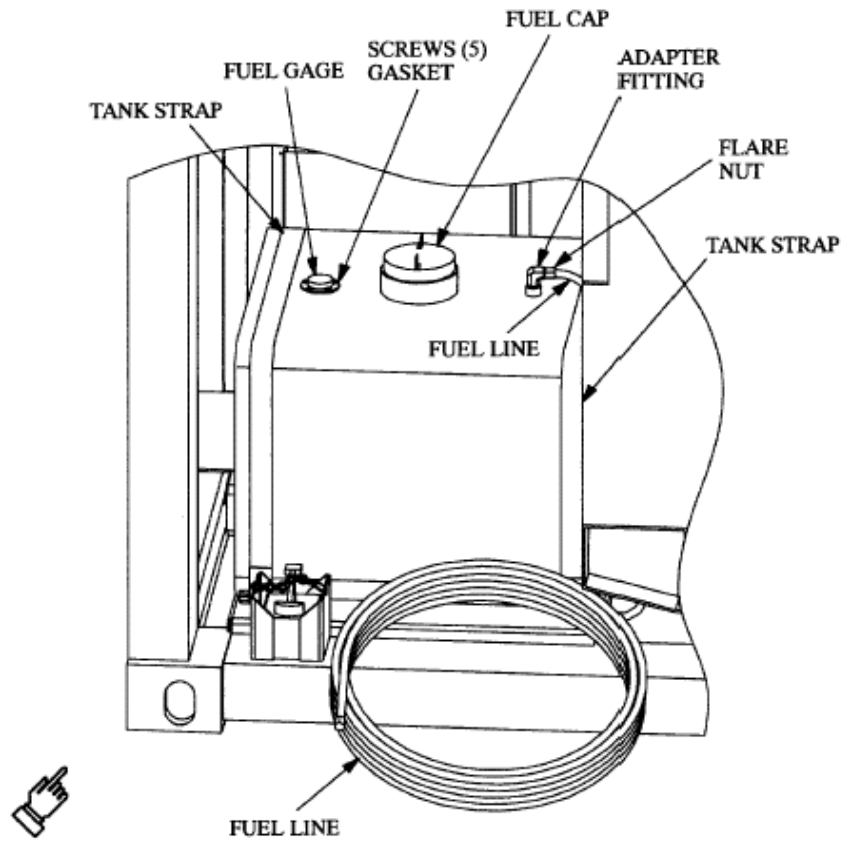

NOTE:

See TM 9-6115-642-10/24 for fuel connection to the 10 KW Tactical Quiet Generator (TQG) Set.

Figure 4-11. Fuel System Components, Removal and Installation.

b. Fuel gauge. See Figure 4-11 for removal and installation.

Section XVI. MAINTENANCE OF POWER CABLE

4-54. General.

The power cable (Figure 4-12) is a heavy duty, insulated wire assembly carrying three phase electric power from the generator set to the refrigeration unit power cable. It has a cable connector on one end for connection to the refrigeration unit cable connector and pigtail leads on the other end for connection to terminals in the generator set terminal box.

4-55. Inspection.

Inspect generator electric cable and connector for obvious damage and defects.

4-56. Removal.

WARNING

Always be sure that the generator set is not operating before attempting to connect or disconnect the power cable. Check to see that all switches are in the “off” or “open” position and that there is no input on the load.

NOTE

Refer to TM 9-6115-642-10/24 for the Tactical Quiet Generator (TQG) set switches, and TM 5-4110-231-14 for the refrigeration unit switches.

a. Disconnect generator electrical cable connector from the refrigeration unit electrical cable connector.

b. Disconnect electric cable leads from generator set terminals and remove cable (TM 9-6115-642-10/24).

4-57. Installation.

WARNING

Always be sure that the generator set is not operating before attempting to connect or disconnect the power cable. Check to see that all switches are in the “off” or “open” position and that there is no input on the load.

NOTE

Refer to TM 9-6115-642-10/24 for the Tactical Quiet Generator (TQG) set switches, and TM 5-4110-231-14 for the refrigeration unit switches.

a. Connect electric cable leads (Figure 4-12) to generator set terminals (TM 9-6115-642-10/24) for 208V, three phase AC power.

NOTE

Observe serial number applicability noted on wiring diagram (Figure 4-12).

b. Connect generator electric cable connector to refrigeration unit cable connector.

Section XVII. MAINTENANCE OF EXHAUST SYSTEM

4-58. General.

The exhaust system (Figure 4-13) consists of shields and rigid steel pipes designed to carry exhaust gases away from the generator set diesel engine. The rigid steel pipes

are connected with U-clamps to the engine exhaust pipe, and have a hinged rain cap for all weather protection. The exhaust shields are mounted over the exhaust system and provides protection from serious burns.

NOTE: CABLE WIRE IS NUMBER 10 SIZE CONDUCTORS WITH GREEN LEAD CUTOFF

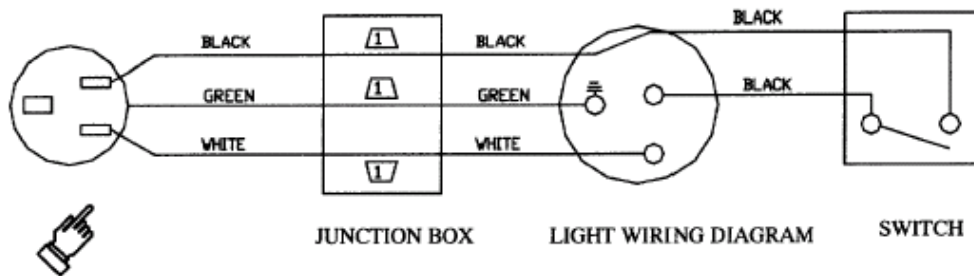
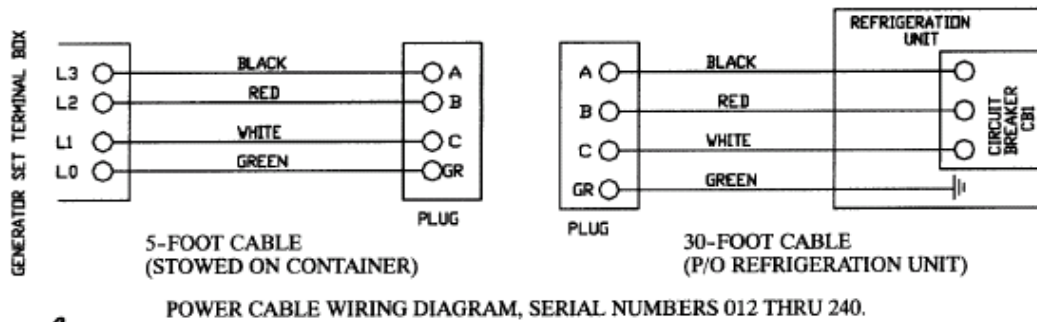
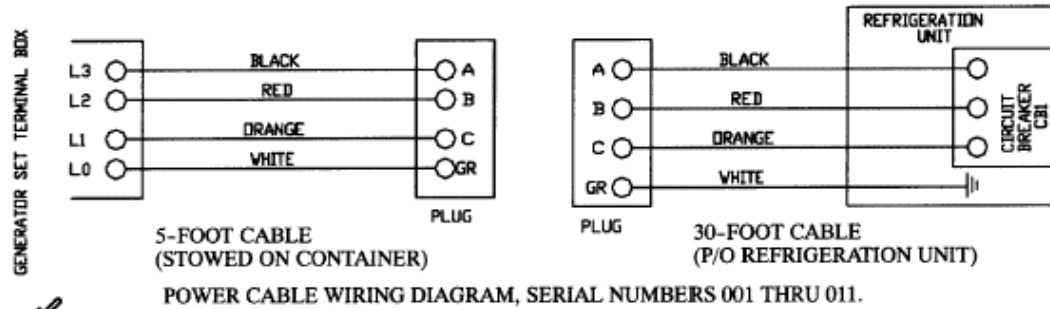

Figure 4-12. Power Cable and Light Wiring Diagram.

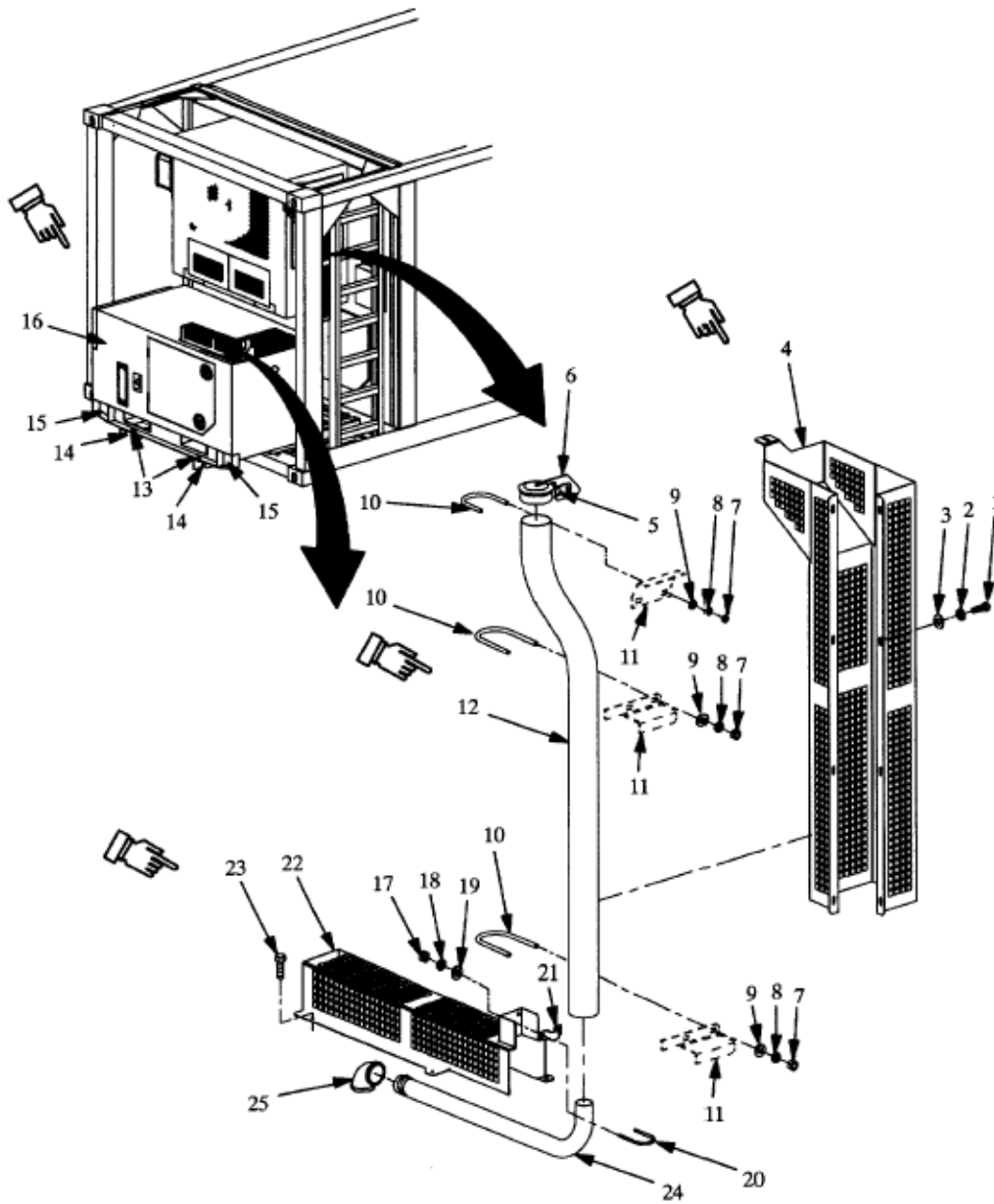

Figure 4-13. Exhaust System Components and Removal and Installation.

4-59. Inspection.

Inspect exhaust shields, exhaust pipes, U-bolts, spacer, and rain cap for obvious leaks, cracks, ruptures and deterioration.

4-60. Removal.**WARNING**

Before performing maintenance on exhaust system be sure that generator is not operating, and that exhaust pipes have cooled to the point where they will not burn personnel.

Refer to Figure 4-13.

a. Remove nine screws (1), nine lock washers (2), nine flat washers (3) and vertical exhaust shield (4). Discard lockwashers.

b. Loosen nut (5) and remove rain cap (6).

c. Remove six nuts (7), six lock washers (8), six flat washers (9) and three U-bolts (10) from brackets (11) and remove vertical exhaust pipe (12). Discard lockwashers.

d. Remove generator locking down bolts (13).

e. Using two personnel, release retention latches (14) simultaneously and pull from both sides on the generator lifting rings (15) until generator (16) slides out and retention latches lock.

f. Remove two nuts (17), two lock washers (18), two flat washers (19), U-bolt (20) and spacer (21) from horizontal shield (22). Discard lockwashers.

g. Remove five screws (23) and horizontal exhaust shield (22).

h. Remove exhaust pipe (24) and elbow (25).

4-61. Installation.

a. Apply anti-seize compound to threads and install horizontal exhaust pipe (24) and elbow (25). Final positioning will be accomplished when exhaust shields and U-bolts are installed.

b. Install horizontal exhaust shield (22) on generator set (16) and secure with five screws (23).

c. Install spacer (21) and U-bolt (20) on horizontal exhaust shield (22) with two nuts (17), two lock washers (18) and two flat washers (19). Do not tighten at this time because of alignment with vertical exhaust shield (4).

NOTE

It may be necessary to move the horizontal exhaust pipe (24) to align the U-bolt (20) and spacer (21) with welded brackets (11).

CAUTION

When the generator set is returned to the stowed position, fuel hose and power cable must be kept clear of slides. Fuel hose and power cable could be damaged if pinched by the slide.

d. Using two personnel, release retention latches (14) simultaneously, carefully push generator set (16) back into the stowed position until latches lock.

e. Install generator locking bolts (13).

f. Install vertical exhaust pipe (12) and secure with three U-bolts (10), six flat washers (9), six lock washers (8) and six nuts (7). Bottom of exhaust pipe should be 1/4 inch above horizontal exhaust pipe (24).

f. Install rain cap (6) and tighten nut (5).

g. Install vertical exhaust shield (4) with nine flat washers (3), nine lock washers (2) and nine screws (1).

CAUTION

The vertical and exhaust pipes should be aligned concentrically (center of the vertical exhaust pipe centered on the horizontal pipe) to prevent water from running down into the generator exhaust.

h. Horizontal exhaust pipe (24) must be able to clear through the vertical exhaust shield (4). If it does not, loosen nuts (17) and push exhaust pipe down until it is clear and secure by tightening nuts (17).

Section XVIII. MAINTENANCE OF REFRIGERATION UNIT

4-64. General.

The refrigeration unit (Figure 1-1) operates as a self-contained, externally power system which cools or heats and circulates the air within the refrigerated container.

4-63. Inspection, Test, Servicing.

See TM 5-4110-231-14 for complete inspection, testing, and servicing data for the refrigeration unit.

4-64. Removal.

a. Stop operation of refrigeration unit (TM 5-4110-231-14).

b. Stop operation of generator set (TM 9-6115-642-10/24).

WARNING

Always be sure that the generator set is not operating before attempting to connect or disconnect the power cable. Check to see that all switches are in the “off” or “open” position and that there is no input on the load.

Refer to Figure 4-14.

c. Disconnect refrigeration unit power cable (1) and position it on cable reel (2) located inside the refrigeration unit (3).

WARNING

Do not try to lift refrigeration unit with forklift while the mounting hardware is still attached. Do not extend forklift tines too far into the refrigeration unit tine guides. Refrigeration unit will be damaged.

d. Position forklift tines in refrigeration unit (3) tine guides (4) so they can support the unit’s weight when the mounting hardware is removed.

e. Open doors (5 and 6) to gain access to mounting hardware.

f. Remove four nuts (7), four lock washers (8) and four flat washers (9). Discard lockwashers.

g. Slowly raise the refrigeration unit (3) with the forklift just enough to take the weight off the mounting studs (10).

CAUTION

Use extreme care removing the refrigeration unit not to damage the evaporator section of

of the refrigeration unit or the frame opening on the container.

h. While pushing the refrigeration unit (3) from inside of the container, remove the refrigeration unit from the opening in the front panel (11).

i. If the refrigeration unit (3) is not replaced immediately, install the cover plate (12) over the opening in the front panel (11).

4-65. Installation.

a. Replace damaged studs (10).

CAUTION

Place personnel inside and outside container to guide the refrigeration unit into position in the front panel. Also, the forklift tines must not protrude beyond the tine guides on the refrigeration unit. Damage to the evaporator section or front panel will occur.

b. If cover plate (12) is installed on front panel (11), remove four nuts (7), four lock washers (8) and four flat washers (9) from studs (10). Stow cover plate inside of container.

c. Apply a bead of adhesive (Appendix E, Item 12) on outside surface of opening on front panel (11).

d. Using forklift, carefully guide the refrigeration unit (3) into position on the front panel (11) and studs (10).

e. Open doors (5 and 6) and install four flat washers (9), four lock washers (8) and four nuts (7) on studs (10).

f. Carefully remove forklift from the refrigeration unit tine guides (4).

g. Open door (6) and remove cable (1) from the cable reel (2).

h. Close container doors.

i. Connect refrigeration cable (1) to the generator cable.

j. Operate generator set (TM 9-6115-642-10/24).

k. Operate refrigeration unit (TM 5-4110-231-14).

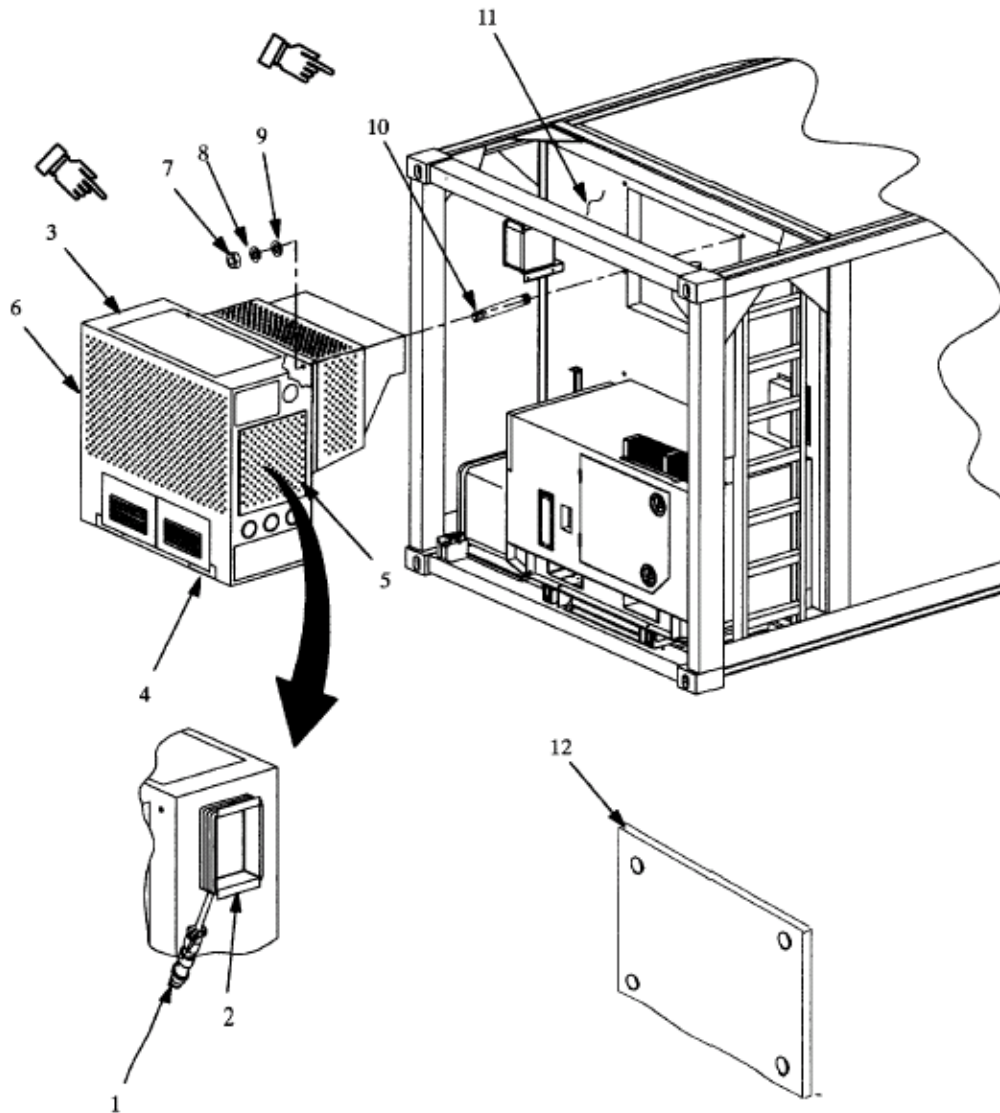

Figure 4-14. Refrigeration Unit, Removal and Installation.

Section XIX. MAINTENANCE OF GENERATOR SET

4-66. General.

The generator set Model MEP-803A is a fully enclosed, self-contained, skid mounted, portable unit. The generator set is equipped with controls, instruments and accessories necessary for operation. The generator set consists of a diesel engine, brushless generator, excitation system, speed governing system, fuel system, 24 VDC starting system, control system and fault system. See TM 9-6115-642-10/24 for descriptive and operating data.

4-67. Inspect.

See TM 9-6115-642-10/24 for complete inspection, testing, and servicing data for the diesel generator set.

4-68. Removal.

WARNING

Always be sure that the generator set is not operating before attempting to connect or disconnect the power cable. Check to see that all switches are in the "off" or "open" position and that there is no input on the load.

See Figure 2-6 for disconnecting ground wire.

a. Disconnect the ground wire from the ground rod the generator set (Refer to paragraph 2-9).

See Figure 4-15 (Sheet 1 of 2) to remove the generator set

b. Remove two generator locking bolts (1) from generator set (2).

c. Disconnect external fuel supply hose (3) from fitting (4) and elbow (5).

d. Install dust caps (6 and 7) on elbow (5) and fitting (6).

e. Drain any fuel in hose (3) into a suitable container.

f. Open storage door (8) and store fuel supply hose (3) in storage compartment, close door.

g. Using two personnel, release retention latches (9) simultaneously and pull both sides on the generator lifting rings (10) until generator set (2) slides out and retention latches lock.

See Figure 4-15 (Sheet 2 of 2) to disconnect power cable from generator set.

h. Tag and disconnect power cable (11) as follows:

(1) Open terminal back door (12).

(2) Remove fastener tool (13).

(3) Raise retention clips (14) from terminals.

(4) Using fastener tool (13), loosen terminal nuts (15) on terminals.

(5) Remove wires from terminals.

(6) Replace fastener tool (13).

i. Loosen weather boot (16) and remove power cable (11) from generator set. Close terminal door (12).

j. Remove four nuts (17), four lock washers (18), eight flat washers (19) and four bolts (20). Discard lock washers.

k. Using forklift, remove generator set (2) from slide rails (21).

See Figure 4-16 for removal of generator set exhaust shield and pipe.

l. Remove two nuts (1), two lock washers (2), two flat washers (3), U-bolt (4) and spacer (5). Discard lockwashers.

m. Remove five screws (6) and horizontal shield (7) from generator set (8).

n. Remove horizontal exhaust pipe (9) and elbow (10) from generator set (8).

4-69. Installation.

See Figure 4-16 for installation of generator set exhaust shield and pipe.

a. Apply anti-seize compound to threads and install horizontal exhaust pipe (9) and elbow (10). Final positioning will be accomplished when exhaust shields and U-bolts are installed.

NOTE

It may be necessary to move the horizontal exhaust pipe to align the U-bolt and spacer with welded brackets.

b. Install horizontal exhaust shield (7) on generator set (8) and secure with five screws (6).

c. Install spacer (5) and U-bolt (4) on horizontal exhaust shield (7) with two flat washers (3), two lock washers (2) and two nuts (1). Do not tighten at this time because of alignment with vertical exhaust shield (4) and vertical pipe (12, Figure 4-13).

See Figure 4-17 (Sheet 1 of 4) for installation of generator set.

d. Using a forklift truck, position generator set (1) on frame slide rails (2).

e. Align mount holes in generator set (1) with mounting holes in generator set slide (2).

f. Install eight flat washers (3), four lock washers (4), four nuts (5) and four bolts (6) to secure generator set (1) to slide rails (2).

See Figure 4-17 (Sheet 2 of 4) for connection power cable to generator set.

g. Connect power cable (7) to generator set (1) as follows:

- (1) Open terminal door (8).
- (2) Insert power cable (7) through weather boot (9) into terminal compartment.
- (3) Remove fastener tool (10). Raise retention clips (11) on terminals.
- (4) Connect black wire to L1.
- (5) Connect white wire to terminal L2.
- (6) Connect red wire to terminal L3.
- (7) Connect green wire to terminal L0.
- (8) If required, insert ground wire through slot on load terminal board marked GND.

h. Tighten nuts on terminals with fastener tool.

i. Place retention clip (11) over each terminal and return fastener tool (10) to storage position.

j. Close terminal door (8). Secure weather boot (9) around cable (7).

See Figure 4-17 (Sheet 3 of 4) for installation of fuel hose.

k. Open storage door (12) and remove fuel hose (13) from storage box.

l. Remove dust cap (14) and connect fuel hose (13) to elbow (15) on fuel tank (16).

m. Remove dust cap (17) and connect fuel hose (13) to external fuel fitting (18).

See Figure 4-17 (Sheet 4 of 4) for installation of generator set.

CAUTION

When generator set is returned to the stowed position, fuel hose and power cable must be kept clear of the slides. Fuel hose and power cable could be damaged if pinched in slide.

n. Using two personnel, release retention latches (19) simultaneously and carefully push generator set (1, Figure 4-17 Sheet 1 of 4) back into stowed position until retention latches locks.

CAUTION

The vertical and exhaust pipes should be aligned concentrically (center of the vertical exhaust pipe centered on the horizontal pipe) to prevent water from running down into the generator exhaust.

o. If exhaust pipe (19) does not clear the vertical shield (20) loosen nuts (1, Figure 4-16) and push exhaust pipe (19) down until it is clear.

p. Secure by tightening nuts (1, Figure 4-16).

q. Install generator locking bolts (21).

r. If required, connect ground wire to generator and ground rod (See paragraph 2-9).

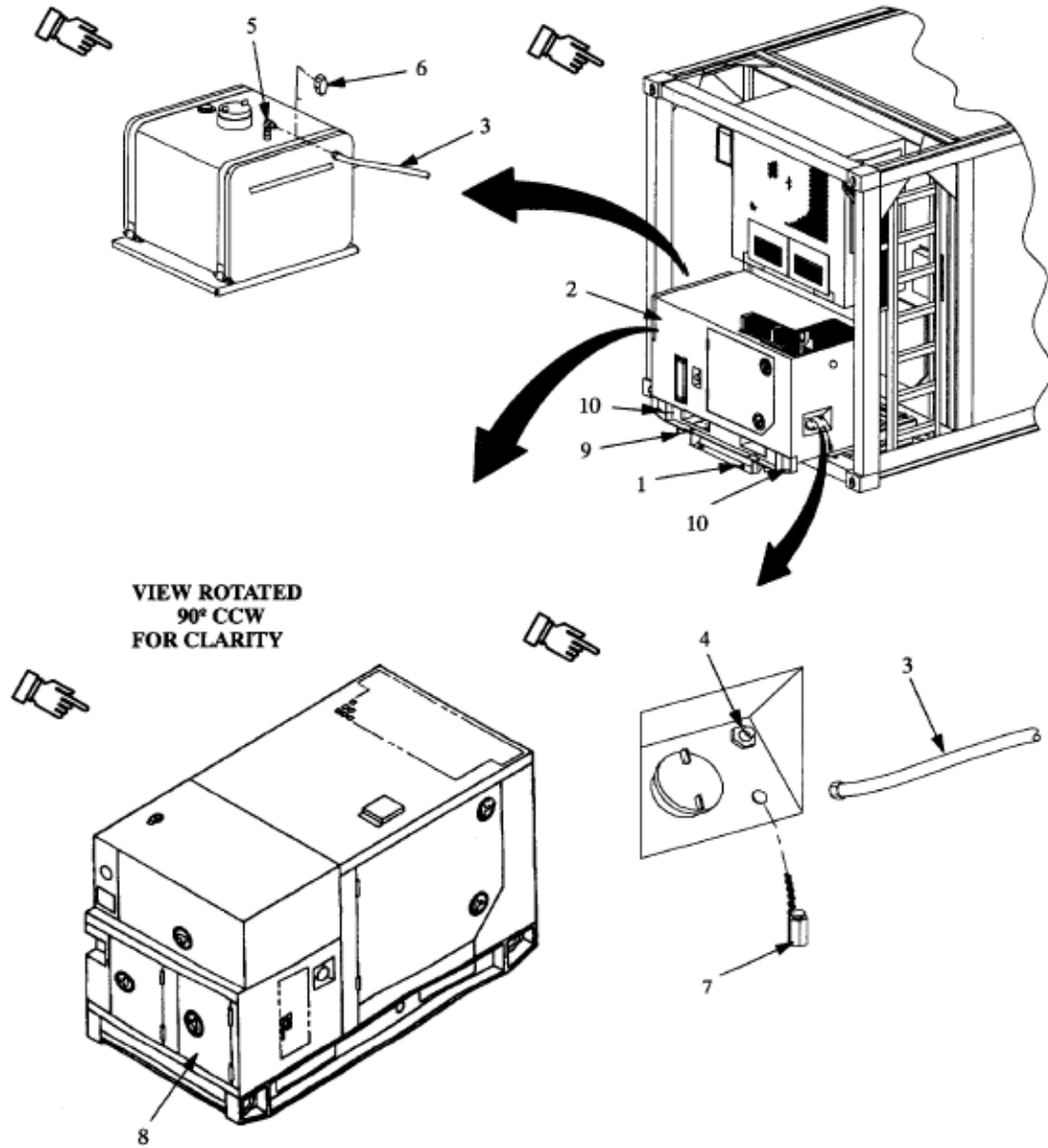

Figure 4-15. Generator Set Removal (Sheet 1 of 2).

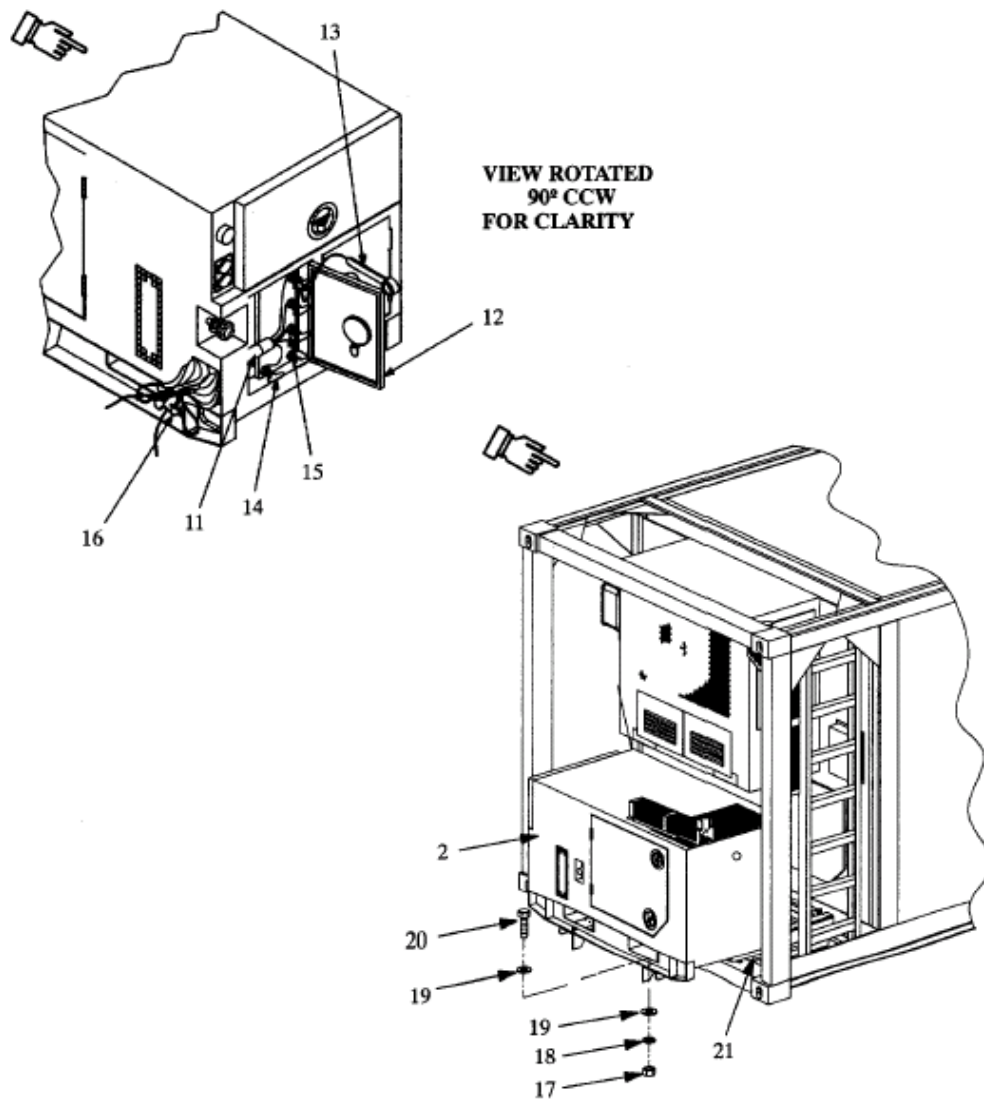

Figure 4-15. Generator Set Removal (Sheet 2 of 2).

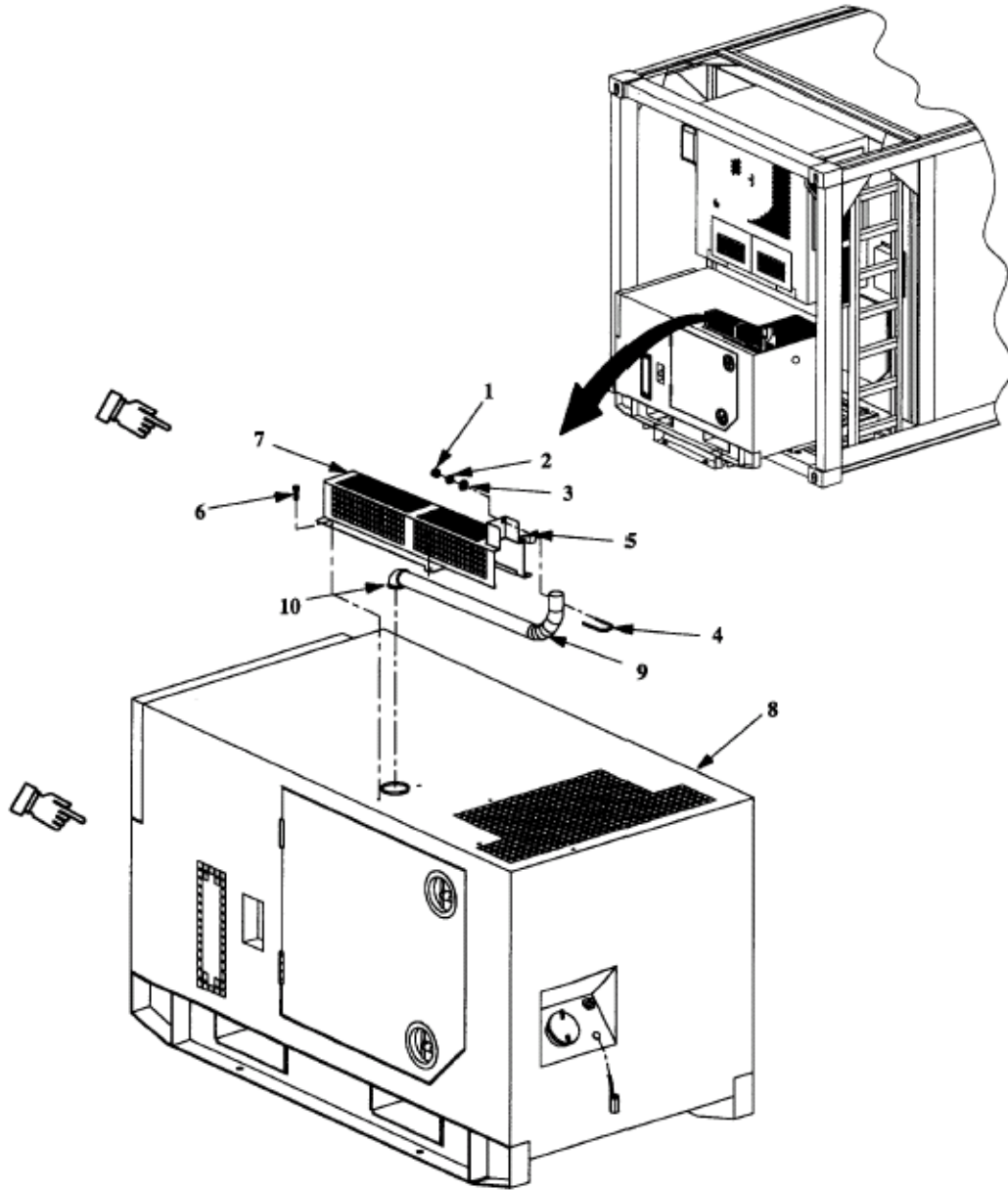

Figure 4-16. Generator Set Exhaust Removal and Installation.

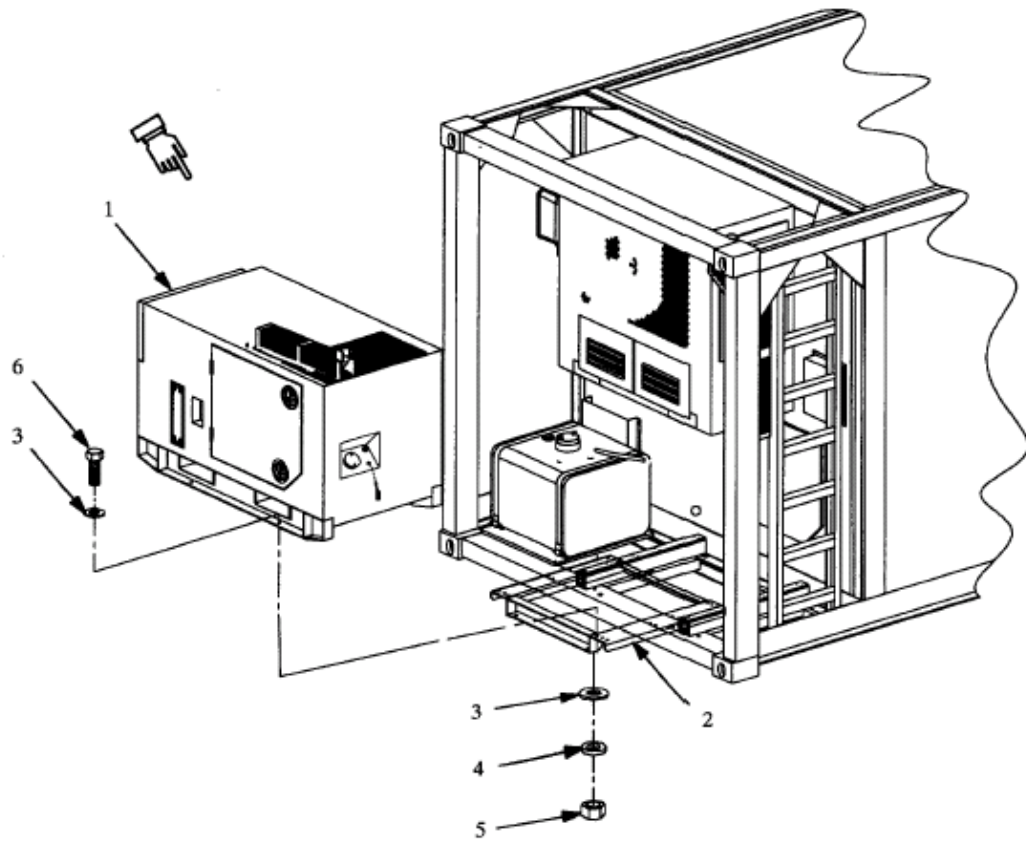

Figure 4-17. Generator Set Installation (Sheet 1 of 4).

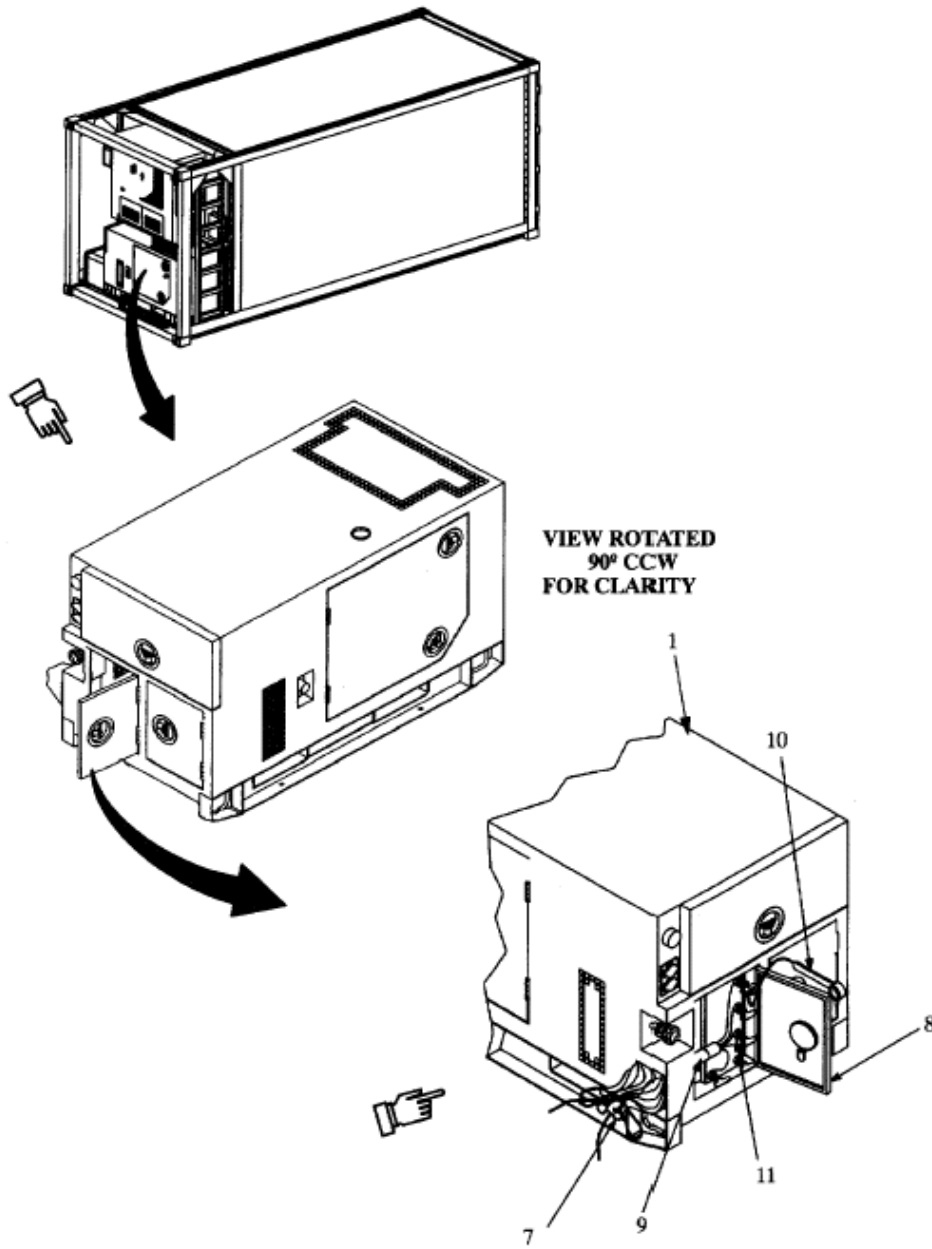

Figure 4-17. Generator Set Installation (Sheet 2 of 4).

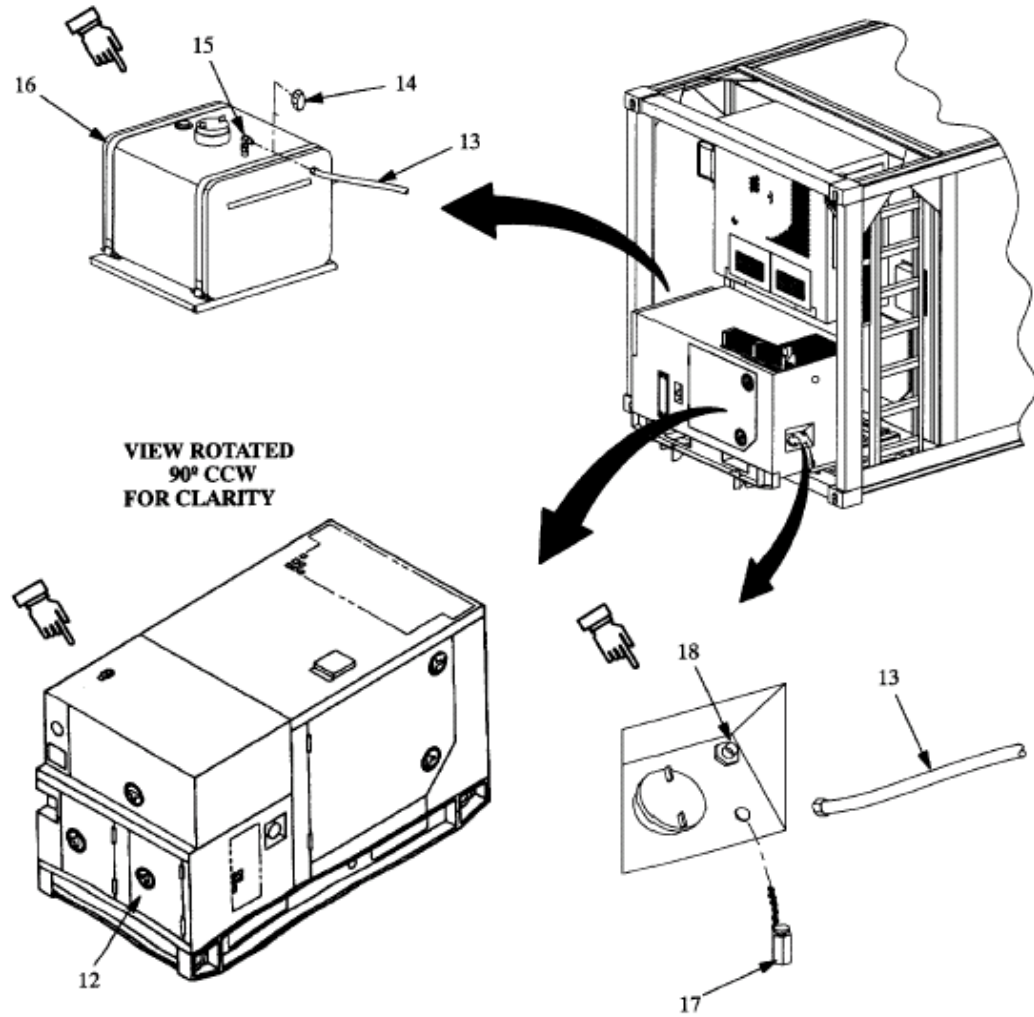

Figure 4-17. Generator Set Installation (Sheet 3 of 4).

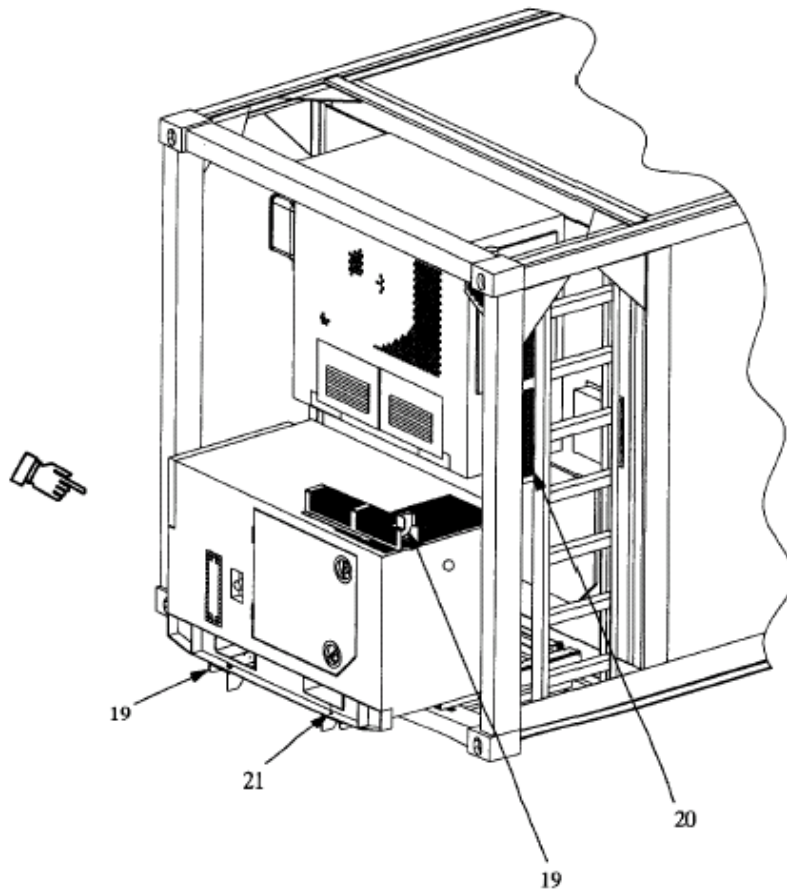

Figure 4-17. Generator Set Installation (Sheet 4 of 4).

Section XX. MAINTENANCE OF GENERATOR SLIDE ASSEMBLY**4-70. General.**

The generator set slide assembly is located in front of the refrigeration container and provides ease of servicing, maintenance, removal and installation of the generator set.

4-71. Inspection.

Inspect generator set slide assembly for obvious damage and defects.

4-72. Removal.

See Figure 4-18 for removal, inspection and installation of the generator slide assembly.

- a. Remove generator set (Refer to paragraph 4-68).
- b. Remove twelve screws (1), twelve lock washers (2), twelve flat washers (3). Discard lock washers.
- c. Remove eight screws (4) and generator mount plate (5).
- d. Remove six screws (6), six lock washers (7), and six flat washers (8) from each of the two slides (9). Discard lock washers.
- e. Remove six screws (10) and three slide mounts (11) from each slide (9).

f. Drill out two rivets (12) and remove two generator locking bolt lanyards (13) from generator mount plate (5).

4-73. Installation.

See Figure 4-18 for installation of the generator slide assembly.

- a. Install three slide mounts (11) on bottom of each slide (9) and secure with six screws (10).
- b. Install two slides (9) on frame (14) and secure with six flat washers (8), six lock washers (7) and six screws (6). Hand tight only at this time.
- c. Position generator mount plate (5) on both slides (9) and secure with twelve flat washers (3), twelve lock washers (2) and twelve screws (1).
- d. Tighten six screws (6) installed in step b.
- e. Secure two generator locking bolt lanyards (13) to generator mounting plate (5) with two rivets (12).
- f. Move generator slide assembly back and forth to ensure each of movement.
- g. Install generator set (Refer to paragraph 4-69).

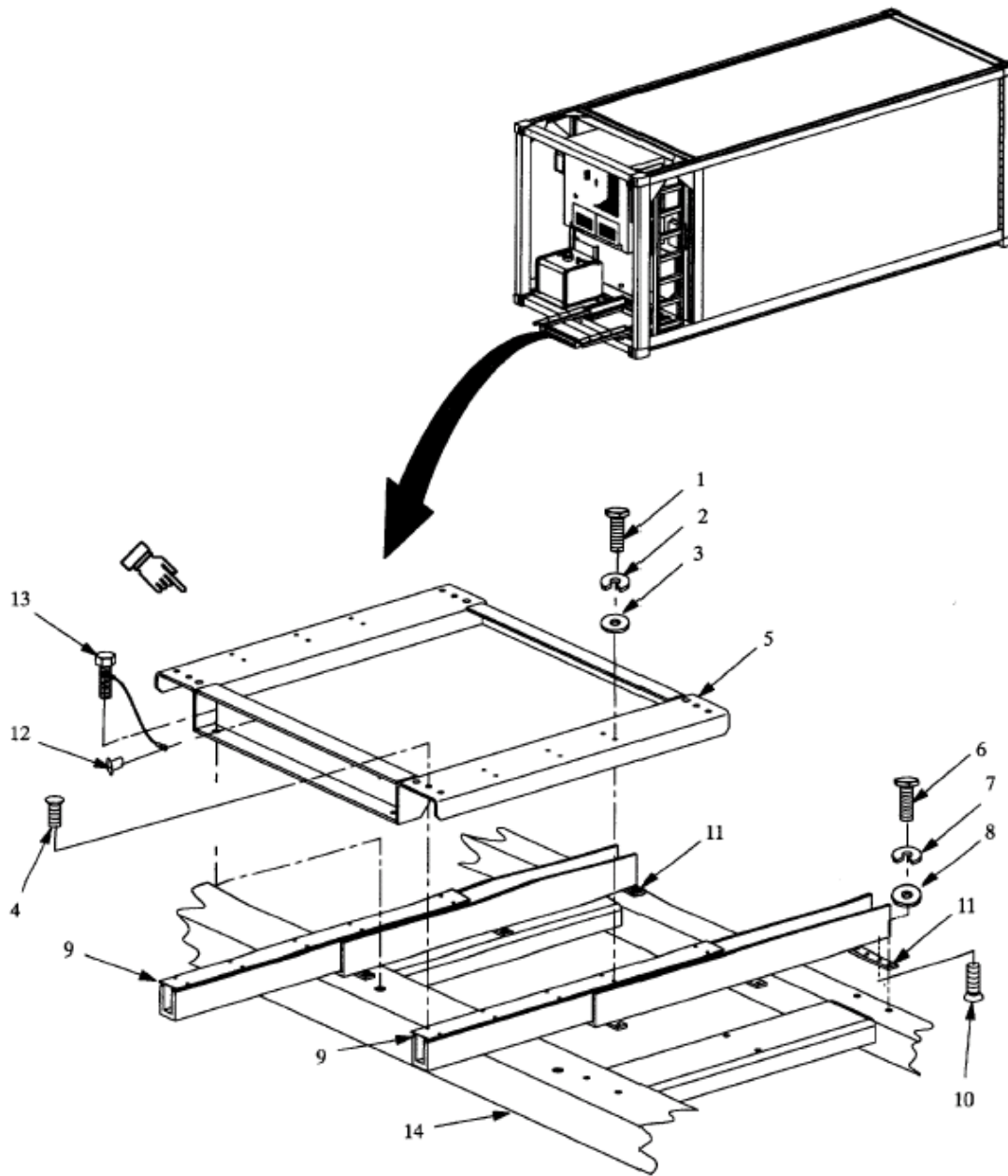

Figure 4-18. Generator Slide Assembly Removal and Installation.

Section XXI. MAINTENANCE OF IDENTIFICATION PLATE**4-74. General.**

The identification plate (Container Data Plate) is located in the rear of the refrigeration container on the outside of the right door assembly.

4-75. Inspection.

Inspect the identification plate for obvious damage and defects.

4-76. Removal.

See Figure 4-19 for removal, inspection and installation of the identification plate.

a. Close right door (1) and left door (2) assemblies.

b. Remove four rivets (3) and identification plate (4) from right door assembly.

4-77. Installation.

See Figure 4-19 for installation of the identification plate.

a. Align holes on the identification plate (4) with rivets hole on the right door (1).

b. Secure identification plate (4) onto the right door (1) with four rivets (3).



REAR OF REFRIGERATION CONTAINER

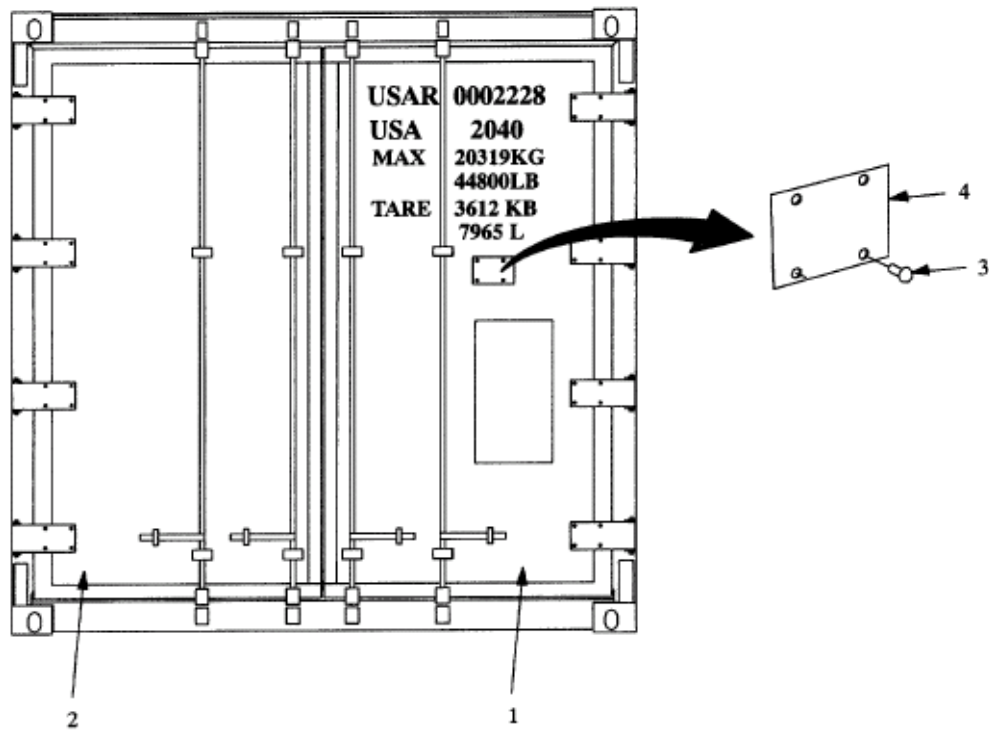

Figure 4-19. Identification Plate Removal and Installation.

**CHAPTER 5
DIRECT AND GENERAL SUPPORT MAINTENANCE INSTRUCTIONS**

Section I. REPAIR PARTS, SPECIAL TOOLS, AND EQUIPMENT

5-1. Tools and Equipment.

Tools and equipment are not issued with the refrigerated container.

5-2. Special Tools and Equipment.

Special tools are required for direct and general support

functions. Refer to paragraph 4-8 for a description of the tools and their use.

5-3. Maintenance and Repair Parts.

Repair parts and equipment are listed and illustrated in TM 55-8115-202-24P.

Section II. TROUBLESHOOTING

5-4. Scope.

This section references information useful in diagnosing and correcting unsatisfactory operation or failure of components of the refrigerated container.

5-5. Troubleshooting.

See Tables 3-2 and 4-1 for malfunction, test or inspection, and corrective action.

Section III. GENERAL MAINTENANCE

5-6. Scope.

This section contains general repair instructions which may be the responsibility of direct and general support maintenance. The instructions cover common maintenance such as surface sealing, undercoat sealing, cleaning and decontamination, and painting of steel and aluminum parts.

5-7. Surface and Undercoat Sealing.

a. Surface Sealing. Seal surfaces of roof, sides, floor and doors of container with polyurethane paint using white color on interior surfaces, and olive drab color (24087 per FED-STD-595) on the exterior surfaces. Apply paint to seal surfaces only where the original fused-on gel coat has been damaged or destroyed.

b. Undercoat Sealing. Apply undercoat sealant, as needed, conforming to federal specification TT-C-520. Undercoating is to be applied over the painted bottom surfaces (floor panel underside and I-beam supports), and should be 1/16-inch thick.

5-8. Cleaning and Decontamination.

a. Container Exterior. Wash with any suitable detergent. Thoroughly rinse with fresh water and allow to air dry.

b. Container Interior. The inside of the container may be cleaned with a light detergent solution and pressure hose, or it may be steam cleaned.

NOTE

Recommended paint is Dupont Imron or equivalent, olive drab color is 24087 per FED-STD-595.

c. Decontamination. Procedures required b, TM 743-200 shall apply.

5-9. Painting.

a. General. Apply paint only for the protection of base metal. Clean and treat surfaces which require paint in accordance with MIL-T-704.

b. Steel Parts. Apply two coats of olive drab, rust-inhibiting, semi-gloss lacquer per MIL-L- 52043, Color 24087 per FED-STD-595.

c. Aluminum Paris. Apply one coat of olive drab semi-gloss paint conforming to FED-STD-595, Color Chip 24037.

Section IV. REMOVAL AND INSTALLATION OF MAJOR COMPONENTS AND AUXILIARIES

5-10. General

The refrigerated container has two container has two auxiliary components and six major components which require special removal and installation procedures.

5-11. Auxiliary 7component3.

a. Generator Set. See paragraphs 4-68 and 4-69 for removal and installation procedures.

b. Refrigeration Unit. See paragraphs 4-64 and 4-65 for removal and installation procedures.

5-12. Major Components.

The major components consists of the roof, sides, front, ribbed flooring, and floor. Except for the ribbed flooring, all these components are one-piece, composite panel constructions (Figure 6-1). The edges of each panel are fastened to the contained box assembly frame with Camtainer fasteners. The ribbed flooring fits over the floor panel.

a. Roof.

(1) Removal.

(a) Remove upper front and side corner angles, the roof zee, and foam insulation (Figure 5-1).

(b) Remove sealant and foam rope gasket around roof panel outer edges.

(c) Remove sealant and foam rope gasket around roof panel outer edges.

(d) Use slings and hoist to remove roof

(e) Remove butyl rubber gasketing stuck to container box frame.

CAUTION

Be careful in removing roof angles and zee. They are adhered to foam insulation.

(2) Installation. Installation is essentially the reverse of removal except as follows:

(a) Use new butyl rubber gasketing between roof panel edges and container box frame.

NOTE

Gasketing is 3M Co. sealant tape, 1202T.

(b) Use new foam rope gasket around roof panel outer edges and seal in-place with a sealant.

NOTE

Recommended sealant is Dow-Corning 732 RTV; rope gasket is Dow-Chemical polyethylene ethafoam, 1/2 inch dia.

b. Sides.

(1) Removal

NOTE

Step (a) applies to removal of right side panel only.

(a) Remove interior light and switch, and conduit.

(b) Remove ribbed flooring (paragraph 5-12), d)

(c) Remove side corner angles, the wall zee, and foam insulation (Figure 5-1).

(d) Support side and remove Camtainer fasteners around edges.

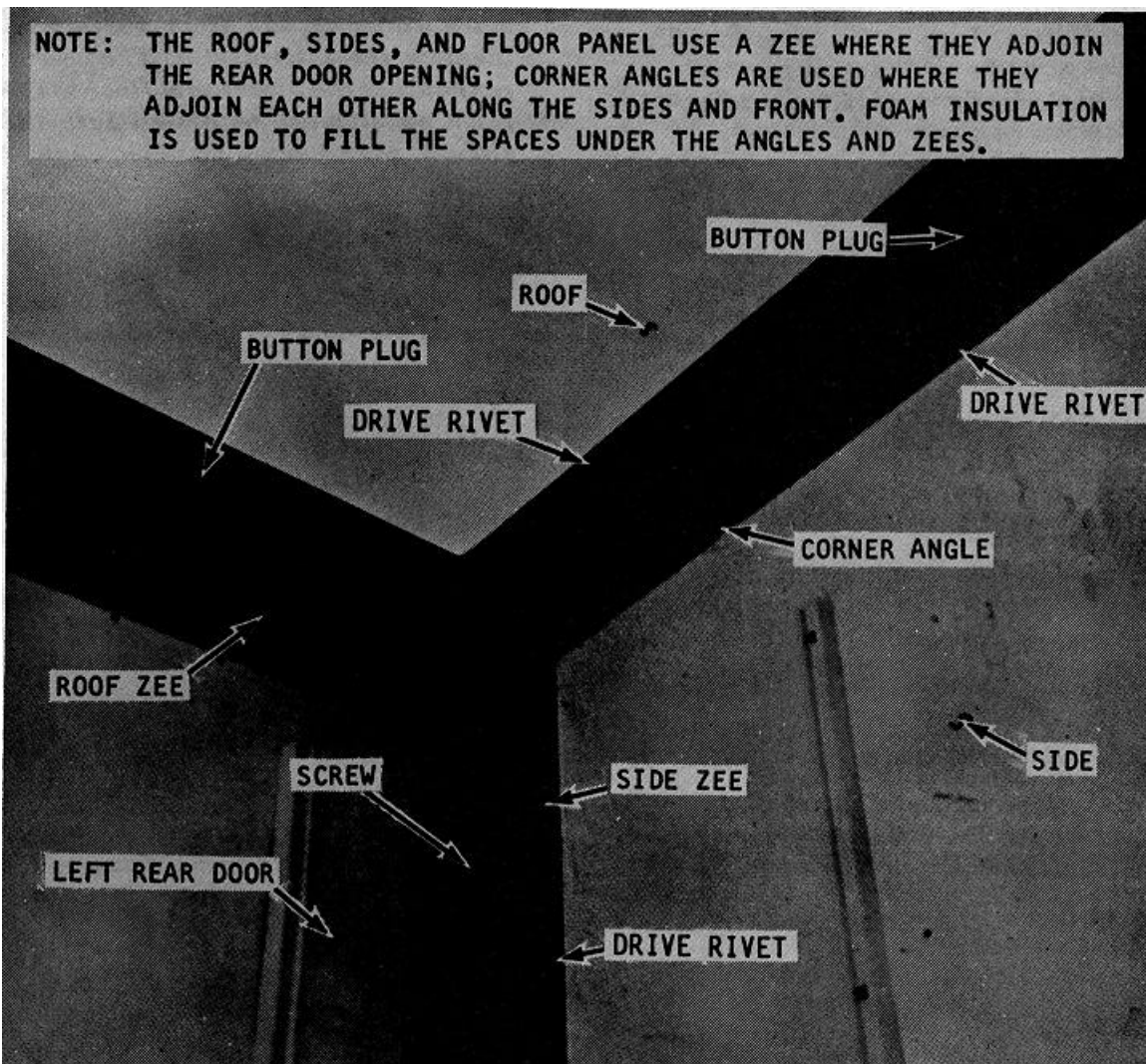

REMOVAL:

- STEP 1. REMOVE OUTER OVERLAPPING CORNER ANGLES FIRST, DRILLING OUT DRIVE RIVETS AND REMOVING SCREWS. CAREFULLY PRY CORNER ANGLE LOOSE.
- STEP 2. REMOVE OTHER CORNER ANGLES AND ZEEs SIMILARLY, AS REQUIRED.
- STEP 3. USE A SHARP TOOL TO CUT AND REMOVE FOAM INSULATION.

INSTALLATION:

- STEP 1. INSTALL INNER UNDERLAPPING ZEEs AND CORNER ANGLES FIRST, USING DRIVE RIVETS AND SCREWS.
- STEP 2. INSTALL OUTER CORNER ANGLES SIMILARLY.
- STEP 3. REMOVE BUTTON PLUGS ON ALL CORNER ANGLES AND ZEEs REPLACED.
- STEP 4. APPLY FOAM INSULATION THROUGH BUTTON PLUG HOLES TO FILL SPACES.
- STEP 5. INSTALL BUTTON PLUGS.

Figure 5-1. Corner Angle and Zee, foam Insulation, Removal and Installation.

- (e) Use slings and hoist to remove side.
- (f) Remove sealant stuck to container box frame.

(2) Installation. Installation is essentially the reverse of removal. Be sure to apply new sealant between side panel edges and container box frame.

NOTE

Sealant is Dow-Corning 732RTV.

c. Front.

NOTE

The refrigeration unit, roof and sides must be removed before the front can be removed (I) Removal (a) Disconnect interior light conduit and wire at front panel (Figure 4-10).

- (b) Remove interior corner angles and foam insulation (Figure 5-1).
- (c) Support front and remove Camtainer fasteners around edges.
- (d) Use slings and hoist to remove front.
- (e) Remove sealant from container box frame.

(2) Installation. Installation is essentially the reverse of removal. Be sure to install new sealant between front panel edges and container box frame.

NOTE

Sealant is Dow-Corning 732RTV.

d. Ribbed Flooring.

(1) Removal

- (a) Remove 1/4 x 1 inch aluminum bar located on door end of floor (Figure 3-1).
- (b) Remove screws holding interlocking floor boards to floor panel.
- (c) Beginning from the right side, remove the ribbed floor boards one by one until the center board is reached; then, remove boards on left side.

NOTE

If a new floor panel is used, prior to securing the ribbed aluminum flooring, mark lines on the floor surface to identify the lateral rib. The screws for holding the aluminum floor to the floor panel must be driven into the rib.

NOTE

If the floor panel is not being replaced, the existing holes are to be used if possible. Or the screws should be aligned with the existing holes on the floor panel (2) Installation.

- (a) Beginning with center ribbed floor board, secure to floor panel using screws.
- (b) Secure remaining floor boards to floor panel as they were removed.
- (c) Apply RTV sealant around entire floor area edges and seams along the front and rear edges between aluminum flooring.
- (d) Weld 1/4 x 1 inch aluminum bar to front edge of floor.

e. Floor.

NOTE

The roof, aides and front, must be removed to gain access to the floor.

- (1) Removal
 - (a) Remove the floor zee (Figure 5-1).
 - (b) Remove Camtainer fasteners around edges.
 - (c) Use slings and hoist to remove floor.
 - (d) Remove butyl rubber gasketing stuck to container box frame.

(2) Installation. Installation is essentially the reverse of removal except as follows:

- (a) Install new butyl rubber gasketing between floor panel and container box frame.

NOTE

Gasketing is 3M Co. sealant tape, 1202T.

- (b) Apply full undercoat to floor underside (paragraph 5-7).

CHAPTER 6 REPAIR INSTRUCTIONS

6-1. General.

This chapter contains instructions for repair of rupture damage to the roof, sides, front, and floor panels. Minor repair instructions for abrasions, scrapes, and punctures are contained in Section XI of Chapter 4.

6-2. Maintenance Evaluation.

It must be determined if repair shall be made with the panel installed in the container, or if removal is necessary. Removal of panels should be avoided if at all possible. Minor damage near or on the end of a panel can usually be repaired; however, extensive damage along fasteners will usually require replacement of the panel. Any rupture damage must be evaluated as to how it affected the overall panel structure; if most of the ribs and bonded joints have been broken, the whole panel should be replaced. Generally, where rupture damage is localized, the panel can be easily repaired. Also, ruptures involving up to half the surface area of a panel can be satisfactorily repaired with the panel installed.

6-3. Rupture Repair.

NOTE

These procedures apply to ruptures into and completely through a panel.

a. Remove panel if necessary (paragraph or weakened plywood around the ruptured area using a bevel cut (Figure 6-1).

NOTE

A hand, keyhole type saw is recommended to cut plywood around ruptures area.

c. Trim damaged insulation and install replacement installation of the same type and thickness, or use FROTH-PAK Kit 9.5, manufactured by INSTA-FOAM Products, Inc., Joliet, Illinois.

d. Replace damage rib sections with same size and type material using a bevel cut, and bond rib in place.

e. Cut replacement piece from repair panel, and bevel cut edges to fit rupture snugly.

NOTE

Repair panels are fiberglass reinforced and come in two thicknesses, 1/2 and 5/8 inch.

f. Install replacement piece using polyester resin on the mating surfaces, and nail in-place.

g. Grind and taper the fiberglass surface (skin only) approximately two inches back on both sides of the rupture perimeter.

h. Cut three layers of 10-oz. glass cloth strips, long enough to cover the 4-inch wide rupture perimeter all around.

NOTE

Use fiberglass repair kit NSN 2090-00-392-6064, and follow application instructions in kit.

i. Use polyester resin to bond the three layers of glass cloth over the rupture area, overlapping the rupture perimeter.

j. Apply polyurethane paint (white inside, olive drab outside) over repair area.

NOTE

Recommended paint is Dupont Imnron or equivalent, olive drab color is 2408 7 per FLD-STD-595.

k. Install panel if removed (paragraph 5-12).

6-4. Edge Repair.

NOTE

Only minor damage on or near the edge, not affecting panel structurally, should be repaired.

a. Remove panel is necessary (paragraph 5-12).

b. Repair abrasions, scrapes, and punctures (paragraph 4-39).

c. Repair ruptures (paragraph 6-3).

d. Install panel if removed (paragraph 5-12).

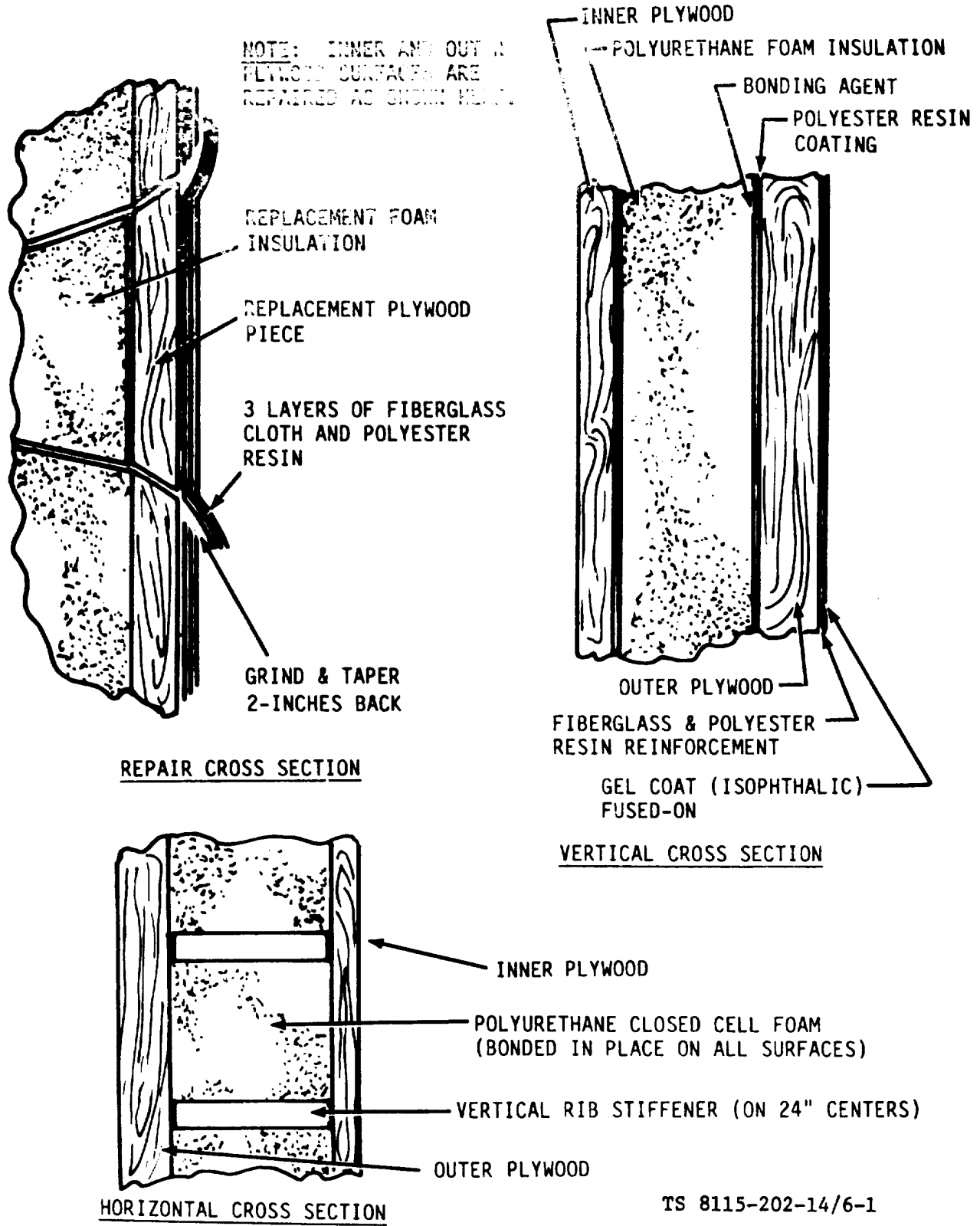

TS 8115-202-14/6-1

Figure 6-1. Rupture Repair of Panel.
6-2

**CHAPTER 7
MAINTENANCE OF MATERIEL USED IN CONJUNCTION WITH THE
REFRIGERATED CONTAINER**

Section I. REFRIGERATION UNIT

7-1. Refer to TM 5-4110-231-14 for maintenance instructions for the refrigeration unit, model CH609-31.

Section II. GENERATOR SET

7-2. Refer to TM 5-6115-585-12/34 for maintenance of the GFE generator set (Diesel engine driven, 10 kw.; 60 Hz).

7-1/(7-2 blank)

This page intentionally left blank.

APPENDIX A

REFERENCES

A-1.	Operation MTMC PAM 55-2	Management and stuffing of Containers
A-2.	Fire Protection TB5-4200-200-10	Hand Portable Fire Extinguishers Approved for Army Users
A-3.	Lubrications C9100-IL	Fuels, Lubricants, Oils and Waxes
A-4.	Painting TM 43-0139	Painting Instructions for Field Use
A-5.	Maintenance TM 5-4110-231-14	Operator's, Organizational, Direct Support and General Support Maintenance Manual for Refrigeration Unit, Electric Motor Driven 9,000 BTU, Model CH609-31
	TM 5-4110-231-24P	Organizational, Direct and General Support Maintenance for Refrigeration Unit, Repair Parts and Tools List, Model CH609-31.
	TM 55-8115-202-24P	Operator's, Organizational, Direct and General Support Maintenance for Refrigerated Container, Repair Parts and Special Tools List, Model SC209.
	TM 9-6115-642-10	Operator's Manual, Generator Set, Skid Mounted, Tactical Quiet, 10 KW, 60 and 400 HZ, MEP-803A (60 HZ) NSN 6115-01-275-5061, MEP-813A (400 HZ) NSN 6115-01-274-7392
	TM 9-6115-642-24	Unit, Direct Support and General Support Maintenance Manual, Generator Set, Skid Mounted, Tactical Quiet, 10 KW, 60 and 400 HZ, MEP-803A (60 HZ) NSN 6115-01-275-5061, MEP-813A (400 HZ) NSN 6115-01-274-7392

TM 9-6115-642-24P

**Unit, Direct Support and General Support
Maintenance, Repair Parts and Special Tools List,
Generator Set, Skid Mounted, Tactical Quiet, 10
KW, 60 and 400 HZ, MEP-803A (60 HZ) NSN
6115-01-275-5061, MEP-813A (400 HZ) NSN
6115-01-274-7392**

**A-6. Shipment and Storage
TB 740-97-2**

**Preservation of USAMEC Mechanical Equipment
for Shipment and Storage**

**A-7. Destruction of Army Equipment
TM 750-244-3**

**Procedures for Destruction of Equipment to
Prevent Enemy Use**

APPENDIX B COMPONENTS OF END ITEMS LIST

Section I. INTRODUCTION

B-1. Scope.

This appendix lists integral components of and basic issue items for the Refrigerated Container to help you inventory items required for safe and efficient operation.

B-2. General.

The Components of End Item List is divided into the following sections:

a. Section II. Internal Components of the End Item. These items, when assembled, comprise the Refrigerated Container and must accompany it whenever it is transferred or turned in. These illustrations will help you identify these items.

b. Section III. Basic Issue Items. These are minimum essential items required to place the Container in operation, to operate it, and to perform emergency repairs. Although shipped separately packed they must accompany the Container during operation and whenever it is transferred between accountable officers. The illustrations will assist you with hard-to-identify items. This manual is our authority to requisition replacement BII, used on Table(s) of Organization and Equipment TOE/Modification Table of Organization and Equipment (MTOE) authorization of the end item.

B-3. Explanation of Columns.

a. Illustration. This column is divided as follows:

(1) Figure Number. Indicates the figure number of the illustration on which the item is shown (if applicable).

(2) Item Number. The number used to identify item called out in the illustration.

b National Stock Number (NSN). Indicates the National Stock Number assigned to the item and which will be used for requisitioning.

c. Part Number (PIN). Indicates the primary number used by the manufacturer, which controls the design and characteristics of the item by means of its engineering drawings, specifications, standards, and inspection requirements to identify an item or range of items.

d. Description. Indicates the Federal item name and, if required, a minimum description to identify the item.

e. Location. The physical location of each item listed is given in this column. The lists are designed to inventory all items in one area of the major item before moving on to an adjacent area.

f Usable on Code. "USABLE ON" codes are included to help you identify which component items are used on different models. Identification of the codes used in these lists are:

CODE

USED ON

g. Quantity Required (Qty Reqd). This column lists the quantity of each item required for a complete major item.

h. Quantity. This column is left blank for use during inventory; Under the Rcv'd column, list the quantity you actually receive on your major item. The Date columns are for use when you inventory the major item at a later date; such as for shipment to another site.

Section II. INTEGRAL COMPONENTS OF END ITEM

(1) Illustration		(2)	(3)	(4)	(5)	(6)	(7)	(8) Quantity		
(a) Figure No.	(b) Item No.	National Stock Number	Part No. & FSCM	Description	Location	Usable On Code	Qty Reqd	Rev'd Date	Date	Date
1-1		6685-01-072-0480	30416 (90598)	Thermometer	Right Front Frame		1			
1-1			30400-100 (90598)	Ladder Side Rear	Right		1			
1-2		5340-01-074-3529	30355-100 (90598)	Door, Escape	Right Rear Door		1			
1-2			30356-100 (90598)	Frame, Door	Right Rear Door		1			
1-1			30414-100 (90598)	Block, Spacer	Right Front Bottom Rail		1			
4-4			30442-100 (90598)	Cable AY	Right Side Front Panel		1			
1-1		2910-01-073-6023	30305-100 (90598)	Tank, Fuel	Right Front Bottom Frame		1			

Change 4 B-2

Section III. BASIC ISSUE ITEMS

(1) Illustration		(2)	(3)	(4)	(5)	(6)	(7)	(8) Quantity			
(a) Figure No.	(b) Item No.	National Stock Number	Part No. & FSCM	Description	Location	Usable On Code	Qty Reqd	Rev'd	Date	Date	Date

N/A

B-3/(B-4 blank)

This page intentionally left blank.

**APPENDIX C
ADDITIONAL AUTHORIZATION LIST**

Section I. INTRODUCTION

C-1. Scope.

This appendix lists additional items you are authorized for the support of the Refrigerated Container.

C-2. General.

This list identifies items that do not have to accompany the Container and that do not have to be turned in with it. These items are authorized to you by CTA, MTOE, TDA or JTA.

C-3. Explanation of Listing.

National Stock Number, descriptions, and quantities are provided to help you identify and request the additional items you require to support this equipment. "USABLE ON" codes are identified as follows:

CODE	USED ON
-------------	----------------

Section II. ADDITIONAL AUTHORIZATION LIST

(1) NATIONAL STOCK NUMBER	PART NUMBER & FSCM	(2) DESCRIPTION	USABLE ON CODE	(3) U/M	(4) QTY AUTH
5130-01-091-3750	480-TX55 93907	Bit, Torx T55 (93907)		ea	1
5120-01-088-8833	TX-5416 93907	Socket, Torx E16 (93907)		ea	1

Change 4 C-2

APPENDIX D

MAINTENANCE ALLOCATION CHART

Section 1. INTRODUCTION

D-1. GENERAL.

- a. This section provides a general explanation of all maintenance and repair function authorized at various maintenance categories.
- b. The Maintenance Allocation Chart (MAC) in Section II designates overall authority and responsibility for performance of maintenance functions on the identified end item or component. The application of the maintenance functions to the end item or component will be consistent with the capacities and capabilities of the designated maintenance levels, which are shown on the MAC in column (4) as:

Unit	Includes two subcolumns, C (operator/crew) O (unit) maintenance
Direct Support	Includes an F subcolumn.
General Support	Includes an H subcolumn.
Depot	Includes a D subcolumn.

- c. Section III lists the tools and test equipment (both special tools and common tool sets) required for each maintenance function as referenced from Section II.
- d. Section IV contains supplemental instructions and explanatory notes for a particular maintenance function.

D-2. MAINTENANCE FUNCTIONS.

Maintenance functions will be limited to and are defined as follows:

- a. Inspect. To determine the serviceability of an item by comparing its physical, mechanical, and/or electrical characteristics with established standards through examination (e.g., by sight, sound, or feel).
- b. Test. To verify serviceability by measuring the mechanical, pneumatic, hydraulic, or electrical characteristics of an item and comparing those characteristics with prescribed standards.
- c. Service. Operations required periodically to keep an item in proper operating condition, i.e., to clean (includes decontaminate, when required), to preserve, to drain, to paint, or to replenish fuel, lubricants, chemical fluids, or gases.
- d. Adjust. To maintain or regulate, within prescribed limits, by bringing into proper or exact position, or by setting the operating characteristics to specified parameters.
- e. Align. To adjust specified variable elements of an item to bring about a optimum performance.

D-2. MAINTENANCE FUNCTIONS – cont.

- f. Calibrate. To determine and cause corrections to be made or to be adjusted on instruments or test, measuring, and diagnostic equipments used in precision measurement. Consists of comparisons of two instruments, one of which is a certified standard of known accuracy, to detect and adjust any discrepancy in the accuracy of the instrument being compared.
- g. Remove/Install. To remove and install the same item when required to perform service or other maintenance functions. Install may be the act of emplacing, seating, or fixing into position a spare, repair part, or module (component or assembly) in a manner to allow the proper functioning of an equipment or system.
- h. Replace. To remove an unserviceable item and install a serviceable counterpart in its place. “Replace” is authorized by the MAC and is shown as the 3rd position code of the SMR code.
- i. Repair. The application of maintenance services, including fault location/troubleshooting, removal/installation, and disassembly/assembly procedures, and maintenance actions to identify troubles, and restore serviceability to an item by correcting specific damage, fault, malfunction, or failure in a part, subassembly, module (component or assembly) end item, or system.
- j. Overhaul. That maintenance effort (service/action) prescribed to restore an item to a completely serviceable/operational condition as required by maintenance standards in appropriate technical publications (i.e., DMWR). Overhaul is normally the highest degree of maintenance performed by the Army. Overhaul does not normally return an item to like new condition.
- k. Rebuild. Consists of those services/actions necessary for the restoration of unserviceable equipment to a like new condition in accordance with original manufacturing standards. Rebuild is the highest degree of material maintenance applied to Army equipment. The rebuild operation includes the act of returning to zero those age measurements (hours/miles, etc.) considered in classifying Army equipment/components.

D-3. EXPLANATION OF COLUMNS IN THE MAC - SECTION II.

- a. Column 1, Group Number. Column 1 lists functional group code numbers, the purpose of which is to identify maintenance significant components, assemblies, subassemblies, and modules with the next higher assembly. End item group numbers are “00”.
- b. Column 2, Component/Assembly. Column 2 contains the names of components, assemblies, subassemblies, and modules for which maintenance is authorized.
- c. Column 3, Maintenance Function. Column 3 lists the functions to be performed on the item listed in Column 2. (For a detailed explanation of these functions, see paragraph B-2).
- d. Column 4, Maintenance Level. Column 4 specifies, by the listing of a work time figure (expressed as man-hours shown as whole hours or decimals) in the appropriate subcolumn(s), the level of maintenance authorized to perform the function listed in Column (3). This figure represents the active time required to perform that maintenance function at the indicated level of maintenance. If the number or the complexity of the tasks within the listed maintenance function vary at different maintenance levels, appropriate work time figures will be shown for each level. The work time figure represents the average time required to restore an item (assembly, subassembly, component, module, end item, or system) to a serviceable condition under typical field operating conditions. This time includes preparation item including any necessary disassembly/assembly time), troubleshooting/fault location time, and quality assurance/quality control time in addition to the time required to perform the specific tasks identified for the maintenance functions authorized in the maintenance allocation chart. The system designations for the various maintenance levels are shown on the following page.

- C..... Operator or crew
- O..... Unit Maintenance
- F..... Direct Support Maintenance
- H..... General Support Maintenance
- D..... Depot Maintenance

- e. Column 5, Tools and Equipment. Column 5 specifies, by code, those common tool sets (not individual tools) common TMDE, and special tools, special TMDE, and support equipment required to perform the designated function.
- f. Column 6, Remarks. This column, when applicable, contains a letter code, in alphabetic order, which is keyed to the remarks contained in Section IV.

D-4. EXPLANATION OF COLUMNS IN TOOL AND TEST EQUIPMENT REQUIREMENTS, SECTION III.

- a. Column 1, Reference Code. The tool and test equipment reference code correlates with a code used in the MAC, Section II, Column 5.
- b. Column 2, Maintenance Level. The lowest category of maintenance authorized to use the tool or test equipment.
- c. Column 3, Nomenclature. Name or identification of the tool or test equipment.
- d. Column 4, National Stock Number. The national stock number of the tool or test equipment.
- e. Column 5, Tool Number. The manufacturer's part number.

D-5. EXPLANATION OF COLUMNS IN REMARKS, SECTION IV.

- a. Column I, Reference Code. The code recorded in column 6, Section II.
- b. Column 2, Remarks. This column lists information pertinent to the maintenance function being performed as indicated in the MAC, Section II.

Section II. MAINTENANCE ALLOCATION CHART

NOMENCLATURE OF END ITEMS
CONTAINER, REFRIGERATED MODEL SC209

(1) Group Number	(2) Component/ Assembly	(3) Maintenance Function	(4) Maintenance Level					(5) Tools & Equip.	(6) Remarks
			UNIT		DS	GS	DEPOT		
			C	O	F	H	D		
00	CONTAINER, REFRIGERATED								
01	DOCUMENT HOLDER AND PLATES								
0101	HOLDER, DOCUMENT	INSPECT	0.1						
		REPLACE		0.5			1,8		
0102	MANUAL HOLDER	INSPECT	0.1						
		REPLACE		0.5			1,8		
0103	IDENTIFICATION PLATE	INSPECT	0.1						
		REPLACE		0.5			8		
02	DOOR AND HARDWARE								
0201	DOOR ASSEMBLY	INSPECT	0.1						
		REPLACE		4.0			1 8	E,F	
		REPAIR	4.0				2,6,7,8	A,C,E	
0202	SEAL, DOOR	INSPECT	0.1						
		REPLACE		4.0			2	A	
		REPAIR		1.0			2	A	
0203	HARDWARE, DOOR	INSPECT	0.1						
		REPLACE		0.5			1,6,7	E	
		REPAIR		8.0			1,6,7	E	
03	SIDES, END AND ROOF								
0301	ROOF PANEL	INSPECT	0.1						
		REPLACE			6.0		1,2,6,7	D	
		REPAIR		2.0			1,2	A,B,C	
0302	SIDE AND END PANELS	INSPECT	0.1						
		REPLACE			8.0		1,2, 6,7	D	
		REPAIR		2.0			1,2	A,B,C,	
0303	CARGO RESTRAINT	INSPECT	0.1						
		REPLACE		2.0			1		
		REPAIR					2		
04	FLOOR								
0401	FLOOR RIB ASSEMBLY	INSPECT	0.1						
		REPLACE		2.0			1,2	B,D	
		REPAIR		3.0				B,D	
0402	FLOOR PANEL	INSPECT	0.1						
		REPLACE		8.0			1,2	D	
		REPAIR		2.0			1,2	AB,C,D	
05	FRAME MEMBERS, SECONDARY								

(1) Group Number	(2) Component/ Assembly	(3) Maintenance Function	(4) Maintenance Level					(5) Tools & Equip.	(6) Remarks
			UNIT		DS	GS	DEPOT		
			C	O	F	H	D		
0501	FRAME ASSEMBLY	INSPECT REPAIR	0.1		8.0			1,2,5	B,F
06	THERMOMETER ASSEMBLY								
0601	THERMOMETER	INSPECT REPLACE TEST REPAIR	0.1	4.0				1,2 3 3	
0602	ELEMENT	INSPECT REPLACE TEST REPAIR	0.1	2.0				1, 2 3 3	
07	FUEL TANK ASSEMBLY		0.1						
0701	TANK, FUEL	INSPECT REPLACE REPAIR	0.1	0.5				1,2 1,2	B,F
0702	CAP, FUEL	INSPECT REPLACE	0.1	0.1				1	
0703	FUEL LINES AND CONNECTIONS	INSPECT REPLACE	0.1					1	
08	EXHAUST PIPES AND EXHAUST SHIELDS								
0801	PIPES, EXHAUST	INSPECT REPLACE REPAIR	0.1	1.0				1,2 1,2 5	B
0802	VERTICAL AND HORIZONTAL SHIELDS	INSPECT REPLACE REPAIR	0.1	1.0				1,2 1,2	B,F
09	ELECTRICAL EQUIPMENT								
0901	CABLE, ELECTRIC POWER	INSPECT REPLACE REPAIR	0.1	1.5				1,2 4	
0902	LIGHT ASSEMBLY	INSPECT REPLACE REPAIR	0.1	1.5				1,2 4	
10	REFRIGERATION UNIT	INSPECT TEST REPLACE REPAIR	0.5	2.0					G G G

(1) Group Number	(2) Component/ Assembly	(3) Maintenance Function	(4) Maintenance Level				(5) Tools & Equip.	(6) Remarks	
			UNIT		DS	GS			DEPOT
			C	O	F	H			D
11	GENERATOR SET, DIESEL	INSPECT TEST SERVICE REPLACE	0.5	2.0				H H	
12	GENERATOR SET SLIDE	REPAIR INSPECT REPLACE REPAIR	0.1	2.0 1.5 1.0			2 1,2,5	H B,F	

Section III. TOOLS AND TEST EQUIPMENT REQUIREMENTS

(1) REFERENCE CODE	(2) MAINTENANCE CATEGORY	(3) NOMENCLATURE	(4) NATIONAL STOCK NUMBER (NSN)	(5) TOOL NUMBER
1	O	Tool Kit, General Mechanics	5180-00-177-7033	SC-5180-90-CL-N26
2	O	Shop Equipment, Automotive Maintenance and Repair: Organizational Maintenance Common No. 1	4910-00-754-0654	SC-4910-95-CL-A72
3	O	Tool Kit, Refrigeration	5180-00-597-1474	SC-5180-90-CL-N18
4	O	Electric Repair Kit	4940-00-294-9517	SC-4940-95-CL-B05
5	F	Welding, Shop, Trailer Mounted	3431-01-090-1231	SC-3431-95-CL-A04
6	O	Socket, Torx	5120-01-088-8833	E16
7	O	Bit, Torx	5130-01-091-3750	T55
8	O	Rivet Tool	5120-00-017-2849	200 or equivalent (100054)

Section IV. REMARKS

REFERENCE CODE	REMARKS
A	Repair accomplished by sealing leaks with sealing compound or patching.
B	Repair accomplished by straightening.
C	Repair accomplishing by patching.
D	Replacement of panel requires special tool for removal of camtainer fasteners.
E	Replacement of door and door hardware requires special tool for removal of camtainer fasteners.
F	Repair accomplished by welding.
G	See Maintenance Allocation Chart (MAC) for end item refrigeration unit, 9000 BTU, Model CH609-31, NSN 4110-01-014-4646, TM 5-4110-231-14.
H	See Maintenance Allocation Chart (MAC) for end item, generator set, skid mounted, diesel powered, tactical quiet (TQ), 10 KW, 60 Hz, Model MEP-803A, NSN 6115-01-275-5061, TM 9-6115--642-10/24.

APPENDIX E**EXPENDABLE SUPPLIES AND MATERIALS LIST****Section I. INTRODUCTION****E-1. SCOPE**

This appendix lists expendable supplies and materials you will need to operate and maintain the container, refrigerated. These items are authorized to you by CTA 50-970, Expendable Items (Except Medical, Class V, Repair Parts, and Heraldic Items).

E-2. EXPLANATION OF COLUMNS

a. Column (1) - Item number. This number is assigned to the entry in the listing and is referenced in the narrative instructions to identify the material (e.g., "Use cleaning compound, Item 1, App. E").

b. Column (2) - Level. This column identifies the lowest level of maintenance that requires the listed item.

(enter as applicable)

C - Operator/Crew
O - Organizational Maintenance
F - Direct Support Maintenance
H - General Support Maintenance

c. Column (3) - National Stock Number. This is the National stock number assigned to the item; use it to request or requisition the item.

d. Column (4) Description. Indicates the Federal item name and, if required, a description to identify the item. The last line for each item indicates the Federal Supply Code for Manufacturer (FSCM) in parentheses followed by the part number.

e. Column (5) Unit of Measure (U/M). Indicates the measure used in performing the actual maintenance function. This measure is expressed by a two-character alphabetical abbreviation (e.g., ea, in, pr). If the unit of measure differs from the unit of issue, requisition the lowest unit of issue that will satisfy your requirements.

(1) Item Number	(2) Level	(3) National Stock Number	(4) Description	(5) U/M
1	0	8040-00-225-4548	SILICONE CAULK RTV 102	OZ
2	0	9150-00-235-5568	GREASE, GRAPHITE, VV-G-671 (81348)	LB
3	O, F, H	2090-00-372-6064	REPAIR KIT, REINFORCE, MILR19907 (81349)	- EA
4	O, F, H	5640-01-122-5010	KIT, URETHANE FOAM, FROTH-PAK KIT 9.5 (54577)	EA
5	0	8040-00-841-9773	ADHESIVE, 520 (03938)	- PT
6	O, F, H	8010-00-297-2124	ENAMEL, COLOR 24087, TT-E-485 (81348)	GL
7	0	8030-01-282-1332	SEALING COMPOUND, RTV 732 (71984)	- PT
8	0	8040-00-777-0631	ADHESIVE, 1C (04347)	- PT
9	F, H	8030-00-221-1834	CORROSION PREVENTIVE COMPOUND, TT-C-520 (81348)	- GL
10	F, H	8010-00-842-5235	LACQUER, COLOR 24087, MIL-L-52043 (81349)	- GL
11	F, H	9320-00-855-3399	TAPE, ADHESIVE, RUBBER 1202T (76381)	FT
12	F, H	8040-00-078-9774	ADHESIVE, 732RTV (71984)	- PT

ALPHABETICAL INDEX

	A	Paragraph
Administrative Storage		1-5
	C	
Cleaning (See Maintenance, General)		
Components (Major), Removal and Installation:		
Floor		5-12e
Front.....		5-12c
Ribbed Flooring		5-12d
Roof.....		5-12a
Sides.		5-12b
Container, Floor, Front, Roof & Sides, Maintenance of:		
General.....		4-37
Inspection		4-38
Repair.....		4-39
Controls and Instruments:		
General.....		2-5
Generator Set		2-8
Rear Doors		2-6a
Refrigeration Unit.....		2-7
Spacer Block		2-6b
Temperature Recorder.....		2-6c
	D	
Decontamination (See Maintenance, General)		
Description		1-5
Destruction of Equipment to Prevent Enemy Use.....		1-4
Door Assembly, Maintenance of:		
General		4-18
Inspection		4-19
Installation		4-22
Removal		4-20
Repair.....		4-21
Door Hardware, Maintenance of:		
General		4-28
Inspection		4-29
Installation		4-32
Removal		4-31
Service.		4-30
Door Seals, Maintenance Of:		
General		4-23
Inspection		4-24
Installation		4-27
Removal		4-25
Repair or Replacement		4-26

Paragraph

E

Equipment Conversion (Electric Operating Power):

- External Power Connection 2-2c
- General 2-2a
- Generator Power Connection 2-2b

Exhaust System, Maintenance of:

- General 4-58
- Inspection 4-59
- Installation 4-61
- Removal 4-60

F

Fuel System, Maintenance of:

- General 4-51
- Inspection 4-52
- Replacement 4-53

G

Generator Set, Maintenance of:

- General 4-66
- Inspection, Test, Service 4-67
- Installation 4-69
- Removal 4-68

H

Holders (Document & Manual), Maintenance of:

- General 4-33
- Inspection 4-34
- Installation 4-36
- Removal 4-35

I

Identification and Tabulated Data:

- Container Data 1-6b(1)
- Generator Set Data 1-6b(4)
- Identification Plates 1-6a
- Refrigeration Unit Data 1-6b(3)
- Temperature Recorder Data 1-6b(2)

Inspecting & Servicing (Operator):

- Inspection 2-1a
- Servicing 2-1b

Inspecting and Service (Organizational):

- Generator Set 4-3a, b
- Inspection 4-1a
- Refrigeration Unit 4-2a, b
- Servicing 4-1b

	Paragraph
Lubrication Instructions (Operators):	
Containers	3-1
Generator Set	3-3
Refrigeration Unit.....	3-2
Lubrication Instructions (Organizational):	
Container	4-11
General	4-10
Generator Set.....	4-13
Refrigeration Unit.....	4-12
-M-	
Maintenance Forms and Records.....	1-3
Maintenance, General	
Cleaning & Decontamination	5-8
Painting.....	5-9
Scope	5-6
Surface and Undercoat Sealing.....	5-7
Movement to a New Worksite:	
Movement.....	2-4
Preparation to Move	2-3
-O-	
Operation of Other Electric Power Source	2-19
Operation of Refrigeration Unit.....	2-20
Operation Under Unusual Conditions	
Normal Operation	2-11
Starting	2-9
Stopping.....	2-10
Operating Under Unusual Conditions:	
Dusty or Sandy Areas	2-14
Extreme Cold.....	2-12
Extreme Heat	2-13
High Altitudes.....	2-17
Rainy or Humid Conditions.....	2-15
Salty Water Areas	2-16
Operation of 10 KW Generator Set (Tactical Quiet) NSN 6115-01-275-5061	2-18
-P-	
Painting (See Maintenance, General)	
Power Cable, Maintenance of:	
General	4-54
Inspection	4-55
Installation	4-47
Removal.....	4-56
Preventive Maintenance (Operator):	
Checks and Services	3-5
General.....	3-4

P (Continued)

Preventive Maintenance (Organizational)	
Checks and Service	4-15
General	4-14

-R-

Refrigeration Unit, Maintenance of	
General	4-62
Inspection, Test, Servicing	4-63
Installation	4-65
Removal	4-64
Repair Instructions:	
Edge Repair	6-4
Evaluation, Maintenance	6-2
General	6-1
Rupture Repair	6-3
Repair Parts	4-9
Reporting Errors	1-4

-S-

Slides, Generator	
General	4-36
Installation	4-36
Removal	4-36
Spacer Strips, Maintenance of	
General	4-40
Inspection	4-41
Replacement	4-42
Special Tools and Equipment	5-2
Storage, Administrative	8-1

-T-

Thermometer Assembly, Maintenance of	
General	4-43
Inspection	4-44
Installation	4-46
Removal	4-45
Thermometer Element, Maintenance of	
General	4-47
Installation	4-50
Removal	4-49
Testing	4-48
Tools and Equipment	4-7
Troubleshooting (Operator)	
General	3-6
Troubleshooting	3-7

Troubleshooting (Organizational)

Scope	4-16
Troubleshooting	4-17

-U-

Under Unusual Conditions, Operation

Operation in High Altitudes.....	2-1
Normal Operation	2-11
Operation in Dusty or Sandy Areas	2-14
Operation in Extreme Cold	2-12
Operation in Extreme Heat	2-137
Operation in Salty Water Areas	2-16
Operation Under Rainy or Humid Conditions	2-15
Starting	2-9
Stopping	2-10

-V-

-W-

Warning	a and b
---------------	---------

-X-

-Y-

-Z-

This page intentionally left blank.

E. C. MEYER
General, United States Army
Chief of Staff

Official:

J. C. PENNINGTON
Major General, United States Army
The Adjutant General

DISTRIBUTION:

To be distributed in accordance with DA Form 12-25C Operator Maintenance Requirements for Refrigeration Equipment.

☆U. S. GOVERNMENT PRINTING OFFICE: 1991 0 - 281-486 (42096)

This page intentionally left blank.

These are the instructions for sending an electronic 2028

The following format must be used if submitting an electronic 2028. The subject line must be exactly the same and all fields must be included; however only the following fields are mandatory: 1, 3, 4, 5, 6, 7, 8, 9, 10, 13, 15, 16, 17, and 27.

From: "Whomever" <whomever@avma27.army.mil>

To: amssbriml @natick.army.mil

Subject: DA Form 2028

1. **From:** Joe Smith
2. **Unit:** home
3. **Address:** 4300 Park
4. **City:** Hometown
5. **St:** MO
6. **Zip:** 77777
7. **Date Sent:** 19-OCT-93
8. **Pub no:** 55-2840-229-23
9. **Pub Title:** TM
10. **Publication Date:** 04-JUL-85
11. **Change Number:** 7
12. **Submitter Rank:** MSG
13. **Submitter FName:** Joe
14. **Submitter MName:** T
15. **Submitter LName:** Smith
16. **Submitter Phone:** 123-123-1234
17. **Problem:** 1
18. **Page:** 2
19. **Paragraph:** 3
20. **Line:** 4
21. **NSN:** 5
22. **Reference:** 6
23. **Figure:** 7
24. **Table:** 8
25. **Item:** 9
26. **Total:** 123
27. **Text:**

This is the text for the problem below line 27.

This page intentionally left blank.

RECOMMENDED CHANGES TO PUBLICATIONS AND BLANK FORMS For use of this form, see AR 25-30; the proponent agency is ODISC4.						Use Part II (<i>reverse</i>) for Repair Parts and Special Tool Lists (RPSTL) and Supply Catalogs/Supply Manuals (SC/SM).	DATE <i>21 October 2003</i>
TO: (<i>Forward to proponent of publication or form</i>) (<i>Include ZIP Code</i>) COMMANDER U.S. ARMY TANK-AUTOMOTIVE AND ARMAMENT COMMAND ATTN: AMSTA LC-CECT KANSAS STREET NATICK, MA 01760-5052						FROM: (<i>Activity and location</i>) (<i>Include ZIP Code</i>) <i>PFC Jane Doe</i> <i>CO A 3rd Engineer BR</i> <i>Ft. Leonardwood, MO 63108</i>	
PART I – ALL PUBLICATIONS (EXCEPT RPSTL AND SC/SM) AND BLANK FORMS							
PUBLICATION/FORM NUMBER TM 10-1670-296-23&P				DATE 30 October 2002	TITLE Unit Manual for Ancillary Equipment for Low Velocity Air Drop Systems		
ITEM NO.	PAGE NO.	PARA-GRAPH	LINE NO. *	FIGURE NO.	TABLE NO.	RECOMMENDED CHANGES AND REASON <i>(Provide exact wording of recommended changes, if possible).</i>	
	0036 00-2				1	<i>In table 1, Sewing Machine Code Symbols, the second sewing machine code symbol should be MD ZZ not MD 22.</i> <i>Change the manual to show Sewing Machine, Industrial: Zig-Zag; 308 stitch; medium-duty; NSN 3530-01-181-1421 as a MD ZZ code symbol.</i>	
<i>*Reference to line numbers within the paragraph or subparagraph.</i>							
TYPED NAME, GRADE OR TITLE Jane Doe, PFC				TELEPHONE EXCHANGE/AUTOVON, PLUS EXTENSION 508-233-4141		SIGNATURE Jane Doe <i>Jane Doe</i>	

TO: <i>(Forward direct to addressee listed in publication)</i> COMMANDER U.S. ARMY TANK-AUTOMOTIVE AND ARMAMENT COMMAND ATTN: AMSTA LC-CECT KANSAS STREET NATICK, MA 01760-5052	FROM: <i>(Activity and location) (Include ZIP Code)</i> <i>PFC Jane Doe</i> <i>CO A 3rd Engineer BR</i> <i>Ft. Leonardwood, MO 63108</i>	DATE 21 October 2003
---	---	--------------------------------

PART II – REPAIR PARTS AND SPECIAL TOOL LISTS AND SUPPLY CATALOGS/SUPPLY MANUALS

PUBLICATION NUMBER TM 10-1670-296-23&P	DATE 30 October 2002	TITLE Unit Manual for Ancillary Equipment for Low Velocity Air Drop Systems
--	--------------------------------	---

PAGE NO.	COLM NO.	LINE NO.	NATIONAL STOCK NUMBER	REFERENCE NO.	FIGURE NO.	ITEM NO.	TOTAL NO. OF MAJOR ITEMS SUPPORTED	RECOMMENDED ACTION
0066 00-1					4			<i>Callout 16 in figure 4 is pointed to a <u>D-Ring</u>. In the Repair Parts List key for figure 4, item 16 is called a <u>Snap Hook</u>. Please correct one or the other.</i>

SAMPLE

PART III – REMARKS

(Any general remarks or recommendations, or suggestions for improvement of publications and blank forms. Additional blank sheets may be used if more space is needed.)

--

TYPED NAME, GRADE OR TITLE	TELEPHONE EXCHANGE/AUTOVON, PLUS EXTENSION	SIGNATURE
----------------------------	--	-----------

<p align="center">RECOMMENDED CHANGES TO PUBLICATIONS AND BLANK FORMS</p> <p>For use of this form, see AR 25-30; the proponent agency is ODISC4.</p>						Use Part II (<i>reverse</i>) for Repair Parts and Special Tool Lists (RPSTL) and Supply Catalogs/Supply Manuals (SC/SM).	DATE
TO: (<i>Forward to proponent of publication or form</i>) (<i>Include ZIP Code</i>) COMMANDER U.S. ARMY TANK-AUTOMOTIVE AND ARMAMENT COMMAND ATTN: AMSTA LC-CECT KANSAS STREET NATICK, MA 01760-5052						FROM: (<i>Activity and location</i>) (<i>Include ZIP Code</i>)	
PART I – ALL PUBLICATIONS (EXCEPT RPSTL AND SC/SM) AND BLANK FORMS							
PUBLICATION/FORM NUMBER TM 55-8115-202-14				DATE 10 AUGUST 1979		TITLE CONTAINER, REFRIGERATED, MODEL SC209 NSN 8115-01-016-5909	
ITEM NO.	PAGE NO.	PARA-GRAPH	LINE NO. *	FIGURE NO.	TABLE NO.	RECOMMENDED CHANGES AND REASON <i>(Provide exact wording of recommended changes, if possible).</i>	
<i>*Reference to line numbers within the paragraph or subparagraph.</i>							
TYPED NAME, GRADE OR TITLE				TELEPHONE EXCHANGE/AUTOVON, PLUS EXTENSION			SIGNATURE

TO: <i>(Forward direct to addressee listed in publication)</i> COMMANDER U.S. ARMY TANK-AUTOMOTIVE AND ARMAMENT COMMAND ATTN: AMSTA LC-CECT KANSAS STREET NATICK, MA 01760-5052	FROM: <i>(Activity and location) (Include ZIP Code)</i>	DATE
---	--	-------------

PART II - REPAIR PARTS AND SPECIAL TOOL LISTS AND SUPPLY CATALOGS/SUPPLY MANUALS

PUBLICATION NUMBER TM 55-8115-202-14	DATE 10 AUGUST 1979	TITLE CONTAINER, REFRIGERATED, MODEL SC209 NSN 8115-01-016-5909
--	-------------------------------	--

PAGE NO.	COLM NO.	LINE NO.	NATIONAL STOCK NUMBER	REFERENCE NO.	FIGURE NO.	ITEM NO.	TOTAL NO. OF MAJOR ITEMS SUPPORTED	RECOMMENDED ACTION

PART III - REMARKS *(Any general remarks or recommendations, or suggestions for improvement of publications and blank forms. Additional blank sheets may be used if more space is needed.)*

TYPED NAME, GRADE OR TITLE	TELEPHONE EXCHANGE/AUTOVON, PLUS EXTENSION	SIGNATURE
----------------------------	--	-----------

<p align="center">RECOMMENDED CHANGES TO PUBLICATIONS AND BLANK FORMS</p> <p>For use of this form, see AR 25-30; the proponent agency is ODISC4.</p>						Use Part II (<i>reverse</i>) for Repair Parts and Special Tool Lists (RPSTL) and Supply Catalogs/Supply Manuals (SC/SM).	DATE
TO: (<i>Forward to proponent of publication or form</i>) (<i>Include ZIP Code</i>) COMMANDER U.S. ARMY TANK-AUTOMOTIVE AND ARMAMENT COMMAND ATTN: AMSTA LC-CECT KANSAS STREET NATICK, MA 01760-5052						FROM: (<i>Activity and location</i>) (<i>Include ZIP Code</i>)	
PART I – ALL PUBLICATIONS (EXCEPT RPSTL AND SC/SM) AND BLANK FORMS							
PUBLICATION/FORM NUMBER TM 55-8115-202-14				DATE 10 AUGUST 1979		TITLE CONTAINER, REFRIGERATED, MODEL SC209 NSN 8115-01-016-5909	
ITEM NO.	PAGE NO.	PARA-GRAPH	LINE NO. *	FIGURE NO.	TABLE NO.	RECOMMENDED CHANGES AND REASON <i>(Provide exact wording of recommended changes, if possible).</i>	
<i>*Reference to line numbers within the paragraph or subparagraph.</i>							
TYPED NAME, GRADE OR TITLE				TELEPHONE EXCHANGE/AUTOVON, PLUS EXTENSION		SIGNATURE	

TO: <i>(Forward direct to addressee listed in publication)</i> COMMANDER U.S. ARMY TANK-AUTOMOTIVE AND ARMAMENT COMMAND ATTN: AMSTA LC-CECT KANSAS STREET NATICK, MA 01760-5052	FROM: <i>(Activity and location) (Include ZIP Code)</i>	DATE
---	--	-------------

PART II - REPAIR PARTS AND SPECIAL TOOL LISTS AND SUPPLY CATALOGS/SUPPLY MANUALS

PUBLICATION NUMBER TM 55-8115-202-14	DATE 10 AUGUST 1979	TITLE CONTAINER, REFRIGERATED, MODEL SC209 NSN 8115-01-016-5909
--	-------------------------------	--

PAGE NO.	COLM NO.	LINE NO.	NATIONAL STOCK NUMBER	REFERENCE NO.	FIGURE NO.	ITEM NO.	TOTAL NO. OF MAJOR ITEMS SUPPORTED	RECOMMENDED ACTION

PART III - REMARKS *(Any general remarks or recommendations, or suggestions for improvement of publications and blank forms. Additional blank sheets may be used if more space is needed.)*

TYPED NAME, GRADE OR TITLE	TELEPHONE EXCHANGE/AUTOVON, PLUS EXTENSION	SIGNATURE
----------------------------	--	-----------

The Metric System and Equivalents

Linear Measure

1 centimeter = 10 millimeters = .39 inch
 1 decimeter = 10 centimeters = 3.94 inches
 1 meter = 10 decimeters = 39.37 inches
 1 dekameter = 10 meters = 32.8 feet
 1 hectometer = 10 dekameters = 328.08 feet
 1 kilometer = 10 hectometers = 3,280.8 feet

Weights

1 centigram = 10 milligrams = .15 grain
 1 decigram = 10 centigrams = 1.54 grains
 1 gram = 10 decigrams = .035 ounce
 1 decagram = 10 grams = .35 ounce
 1 hectogram = 10 decagrams = 3.52 ounces
 1 kilogram = 10 hectograms = 2.2 pounds
 1 quintal = 100 kilograms = 220.46 pounds
 1 metric ton = 10 quintals = 1.1 short tons

Liquid Measure

1 centiliter = 10 milliliters = .34 fl. ounce
 1 deciliter = 10 centiliters = 3.38 fl. ounces
 1 liter = 10 deciliters = 33.81 fl. ounces
 1 dekaliter = 10 liters = 2.64 gallons
 1 hectoliter = 10 dekaliters = 26.42 gallons
 1 kiloliter = 10 hectoliters = 264.18 gallons

Square Measure

1 sq. centimeter = 100 sq. millimeters = .155 sq. inch
 1 sq. decimeter = 100 sq. centimeters = 15.5 sq. inches
 1 sq. meter (centare) = 100 sq. decimeters = 10.76 sq. feet
 1 sq. dekameter (are) = 100 sq. meters = 1,076.4 sq. feet
 1 sq. hectometer (hectare) = 100 sq. dekameters = 2.47 acres
 1 sq. kilometer = 100 sq. hectometers = .386 sq. mile

Cubic Measure

1 cu. centimeter = 1000 cu. millimeters = .06 cu. inch
 1 cu. decimeter = 1000 cu. centimeters = 61.02 cu. inches
 1 cu. meter = 1000 cu. decimeters = 35.31 cu. feet

Approximate Conversion Factors

<i>To change</i>	<i>To</i>	<i>Multiply by</i>	<i>To change</i>	<i>To</i>	<i>Multiply by</i>
inches	centimeters	2.540	ounce-inches	Newton-meters	.007062
feet	meters	.305	centimeters	inches	.394
yards	meters	.914	meters	feet	3.280
miles	kilometers	1.609	meters	yards	1.094
square inches	square centimeters	6.451	kilometers	miles	.621
square feet	square meters	.093	square centimeters	square inches	.155
square yards	square meters	.836	square meters	square feet	10.764
square miles	square kilometers	2.590	square meters	square yards	1.196
acres	square hectometers	.405	square kilometers	square miles	.386
cubic feet	cubic meters	.028	square hectometers	acres	2.471
cubic yards	cubic meters	.765	cubic meters	cubic feet	35.315
fluid ounces	milliliters	29,573	cubic meters	cubic yards	1.308
pints	liters	.473	milliliters	fluid ounces	.034
quarts	liters	.946	liters	pints	2.113
gallons	liters	3.785	liters	quarts	1.057
ounces	grams	28.349	liters	gallons	.264
pounds	kilograms	.454	grams	ounces	.035
short tons	metric tons	.907	kilograms	pounds	2.205
pound-feet	Newton-meters	1.356	metric tons	short tons	1.102
pound-inches	Newton-meters	.11296			

Temperature (Exact)

°F	Fahrenheit	5/9 (after	Celsius	°C
	temperature	subtracting 32)	temperature	

PIN: 043396-000